



OPERATION MANUAL

Combined heat and power unit neoTower®
Status 01.2024

50.0

Contents

Contents

1. Document information	4	5. Assembly	14
1.1 Validity	4	5.1 Safety instructions for assembly	14
1.2 Supporting documents	4	5.2 Installation location requirements	14
1.3 Safety instructions	5	5.2.1 Overview of the installation location .	14
1.4 Explanation of symbols	5	5.2.2 Installation room	15
2. Safety information	6	5.2.3 Heating system	16
2.1 Intended use	6	5.2.4 Flue gas routing	17
2.2 Authorised target groups	6	5.2.5 Exhaust air duct	17
2.2.1 Manufacturer	6	5.2.6 Supply air supply	17
2.2.2 Operator	6	5.2.7 Gas supply	17
2.2.3 Trained personnel	6	5.2.8 Water supply	17
2.2.4 User	6	5.2.9 Condensate drain	18
2.3 General safety instructions	7	5.2.10 Power supply	18
3. Product information	8	5.2.11 Remote monitoring	18
3.1 Functional principle	8	5.3 Assembly steps	18
3.2 Registering with the energy provider	8	5.3.1 Preparing for assembly	18
3.3 Modes of operation	8	5.3.2 Unpacking the system	19
3.3.1 Ready for e-car charging button	8	5.3.3 Positioning the generation unit	19
3.3.2 Summer operation	8	5.3.4 Screwing the control cabinet in position	19
3.3.3 Heat-optimised	8	5.3.5 Screwing the expansion tank connection block in position	20
3.3.4 Electricity-optimised	8	5.3.6 Connecting the generation unit (50.0 Standard, 50.0 High temperature) 20	
3.3.5 Shutdown	8	5.3.7 Connecting the generation unit (50.0 Calorific value) 23	
3.4 Product variants	9	5.3.8 Connecting the temperature sensors 28	
3.5 Scope of supply	9	5.3.9 Connecting the modem	29
3.6 Product overview	10	5.3.10 Connecting the battery	29
3.6.1 Generation unit	10	5.3.11 Connecting the control cabinet	30
3.6.2 Control cabinet	11	5.3.12 Checking the connections	30
3.6.3 Modem	11		
3.6.4 MAG connection group	11		
3.6.5 Calorific value heat exchanger (only with variant "50.0 Calorific value")	12		
3.7 Safety devices	12		
4. Storage	13		
		6. Commissioning	31
		7. Operating	32
		8. Cleaning	33

9.	Service repairs	34
9.1	Maintenance	34
9.2	Fault resolution	34
9.3	Repair	34
10.	Disassembly	35
11.	Disposal	36
11.1	Disposing of packaging	36
11.2	Disposing of the system	36
12.	Appendix	37
12.1	Technical data	37
12.2	Hydraulic diagrams	37
12.2.1	Heating system variant 1 – 1 CHP, 1 buffer tank, peak load boiler connected to buffer tank via hydraulic separator	38
12.2.2	Heating system variant 2 – 1 CHP, 2 buffer tanks, peak load boiler connected to buffer tank via hydraulic separator	39
12.2.3	Heating system variant 3 – 2 CHP, 2 buffer tanks, peak load boiler connected to buffer tank via hydraulic separator	40

Document information

1. Document information



1.1 Validity

Original operation manual. In this manual, the word “system” or “CHP” is used to denote the product.

This manual is valid for the following products:

- 50.0 Standard (Natural and liquid gas)
- 50.0 High temperature (Natural and liquid gas) – 50.0 Calorific value (Natural and liquid gas)

The descriptions are identical for all products; any differences are specifically highlighted.

The illustrations show the product “50.0 Standard”.

This manual is protected by copyright law.

Duplication, reproduction and transmission is only permitted with the permission of the manufacturer.

Subject to change without notice.

1.2 Supporting documents

Additional documents belong to this operation manual and must be observed.

System documentation

The documentation valid for the delivered system (e.g. technical data, maintenance plan) is included in the scope of delivery.

“RMB/Control” operating manual

The “RMB/Control” operating manual describes how to control the system via the operational display and is included in the scope of delivery.

Wiring diagrams

The wiring diagrams are located on the inside of the control cabinet door.

Manuals for system components

The manuals for the supplied system components (e.g. modem) are included in the scope of delivery.

Manuals for accessories

The manuals for optional accessories (e.g. flue gas silencer, exhaust air kit) are provided with each product.

Maintenance manual

The maintenance manual describes specific tasks for maintaining the system that must only be performed by the manufacturer or a specialist partner authorised by the manufacturer. The maintenance manual is not included in the scope of delivery.

Further documents and information (e.g. forms, planning notes, technical drawings) are available on the manufacturer's website.

➔ www.rmbenergie.com

1.3 Safety instructions

⚠ DANGER!

Information highlighted with the word DANGER warns against a hazardous situation that will lead to death or severe injury.

⚠ WARNING!

Information highlighted with the word WARNING warns against a hazardous situation that can lead to death or severe injury.

⚠ CAUTION!

Information highlighted with the word CAUTION warns against a situation that can lead to minor or moderate injuries.

⚠ ATTENTION!

Information highlighted with the word ATTENTION warns against a situation that can lead to material or environmental damage.

1.4 Explanation of symbols

Text

- ▶ Required action
- List
- Cross reference to another point in this document
- 📄 Cross reference to other documents that must be observed
- 🌐 Internet link

Illustrations

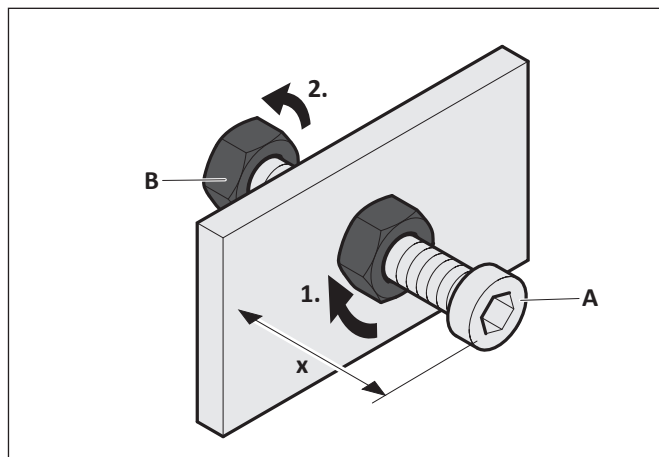

- 1. Numbered action sequence
- A Part designations with upper case letters
- x Dimensions with lower case letters or units in mm
- ↪ Arrows indicating movement and direction

Safety information

2. Safety information



2.1 Intended use

The system is a combined heat and power unit for generating electricity and heat. The system is intended exclusively for incorporation in heating circuits in buildings.

The system is designed for bivalent operation, i.e. it must be combined with an additional heat source ("peak load boiler") in order to operate.

The system is designed for the following energy demand.

System	Annual energy requirement	
	Electricity kWh	Heat kWh
50.0 Standard	275,000	750,000
50.0 High temperature	275,000	750,000
50.0 Calorific value	275,000	750,000

The system is only permitted for use in a technically sound condition once it has been commissioned by the manufacturer or a specialist partner authorised by the manufacturer.

Intended use also includes reading and following this manual.

Any other use is considered contrary to intended use.

2.2 Authorised target groups

This manual is intended for various target groups that are authorised for specific duties.

2.2.1 Manufacturer

The manufacturer supplies the product and has the following duties:

- Training experts on assembly, maintenance, disassembly and disposal.
- Commissioning the system.

Only the manufacturer and specialist partner authorised by the manufacturer have access to the "Experts" area of the "RMB/Control" control mechanism.

2.2.2 Operator

The operator is responsible for the building in which the product is installed. The operator has the following duties:

- Fulfilling the requirements specified by the energy provider (e.g. registration, approval, compensation).
- Meeting the installation location requirements.
- Training the user.
- Complying with statutory occupational health and safety obligations.
- Complying with the valid safety, accident prevention and environmental protection regulations.
- Providing and complying with the documentation.
- Ensuring that the product is always kept in a technically sound condition.
- Storing the system when necessary.

2.2.3 Trained personnel

Trained personnel are responsible for the assembly, maintenance, disassembly and disposal of the product.

The following points must be observed:

- All tasks must only be performed by qualified personnel who have been trained by the manufacturer and who are familiar with assembly technology, gas and water installations, and current safety regulations.
- Special installation tasks (e.g. tasks involving the building structure or the ventilation system) must only be performed by the suitably qualified personnel of specialist companies.
- Electrical installations must only be performed by qualified, skilled electricians.

Only qualified personnel trained by the manufacturer have access to the "Specialist" area of the "RMB/Control" control mechanism.

2.2.4 User

Users may perform operational and cleaning tasks on this product. Obligations of the user:

- To be trained on the product by the operator.
- To be familiar with this manual.

Trained users have access to the non-protected areas of the "RMB/Control" control mechanism, but not to the "Experts" and "Specialist" areas.

2.3 General safety instructions

⚠ WARNING!

Hazard caused by failing to observe the manual!

This manual contains important information for handling the system safely. Potential hazards are specifically highlighted. Failing to observe such information can lead to death or severe injuries.

- ▶ Read the manual carefully.
- ▶ Follow the safety instructions contained in this manual.
- ▶ Follow the safety instructions on the system
- ▶ Store the manual in an accessible place.

If you can smell gas, immediately proceed as follows:

- Close the gas valve.
- Do not generate any naked flames.
- Do not operate any electrical switches (e.g. light switches, all-pole separating points).
- Do not use any electrical appliances in the hazardous area (e.g. telephone).
- Ventilate the rooms.
- Inform the manufacturer, gas utility company or qualified service company.

Use of the system is prohibited in the following cases:

- If the system or individual components are damaged.
- If the system has been altered or modified without authorisation.
- If the supply and return lines (e.g. gas, flue gas, water, electricity, condensate drain) are altered or modified without authorisation.
- If any safety devices are missing or inoperable.
 - “3.6 Product overview” (page 10).
- During the construction phase of the building.
- If the system has been in storage for more than 12 months after delivery without the reapplication of preservative agent by the manufacturer.
 - “4. Storage” (page 13).
- For children or individuals who are incapable of assessing the hazards associated with operating the system.

The manufacturer does not accept any liability or guarantee for damage or loss in the following cases:

- Failing to observe this manual.
- Contrary-to-intended use.
- Improper handling.
- Use by unauthorised target groups.
- Failing to meet the installation location requirements.
- Using components that have not been approved by the manufacturer.
- Bypassing the system’s safety devices.
- Removing the system’s seals and sealants.
- Failing to comply with the maintenance intervals.

Additional safety instructions are provided in the respective chapters of this manual.

- “4. Storage” (page 13).
- “5. Assembly” (page 14).
- “6. Commissioning” (page 31).
- “7. Operating” (page 32).
- “8. Cleaning” (page 33).
- “9. Service repairs” (page 34).
- “10. Disassembly” (page 35).
- “11. Disposal” (page 36).

3. Product information



3.1 Functional principle

The combustion of gas in an industrial gas engine powers a high-performance alternator that produces electricity.

The heat that is generated by this process is used for hot water provision and heating.

This principle is referred to as combined-heat-and-power.

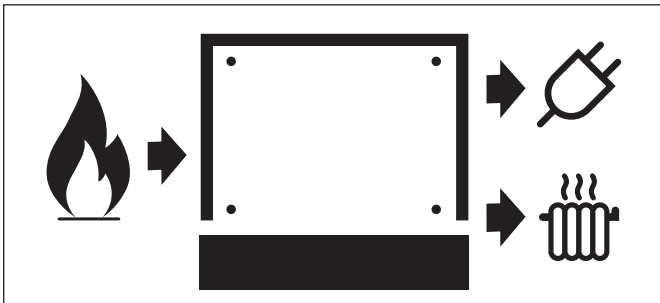

The control mechanism manages and monitors the combustion process in the generation unit. The system is operated via the operational display on the control cabinet.

3.2 Registering with the energy provider

The energy provider must be informed about the installation of the system. Obligations of the operator:

- ▶ Inform the energy provider about the system before it is assembled.
- ▶ Fulfil the requirements specified by the energy provider (e.g. registration, approval, compensation).
- ▶ Provide the energy provider with all the relevant system data.

📄 Technical data.

The electricity produced over and above the operator's own requirement can be fed into the energy provider's local electricity network in return for compensation. A suitable application must be submitted to the energy provider for this purpose.

3.3 Modes of operation

The system can be operated in five modes of operation (including shutdown). The modes of operation are set via the operational display.

📄 "RMB/Control" operating manual.

3.3.1 Ready for e-car charging button

Special mode for charging electric vehicles. Pressing the electric vehicle charging button starts the system in a warm-up phase. Once this warm-up phase is complete, the system runs under nominal load within its pre-set parameters.

If the buffer charge exceeds a certain value, the system switches over to modulation operation.

The electric vehicle charging button can be used by the responsible chimney sweep to perform measurements under nominal load.

3.3.2 Summer operation

In summer operation mode, the system only operates at minimum capacity. The system only starts if the storage battery has insufficient charge.

3.3.3 Heat-optimised

The system starts if a temperature requirement has been set. If the storage battery has reached a specific percentage charge, the system begins to power down steplessly.

3.3.4 Electricity-optimised

The system starts to operate according to a temperature requirement. Once a specific storage battery charge has been reached, the system aligns itself to the electricity consumption of the building.

3.3.5 Shutdown

The system is in hibernation mode. The system does not start according to temperature requirements.

3.4 Product variants

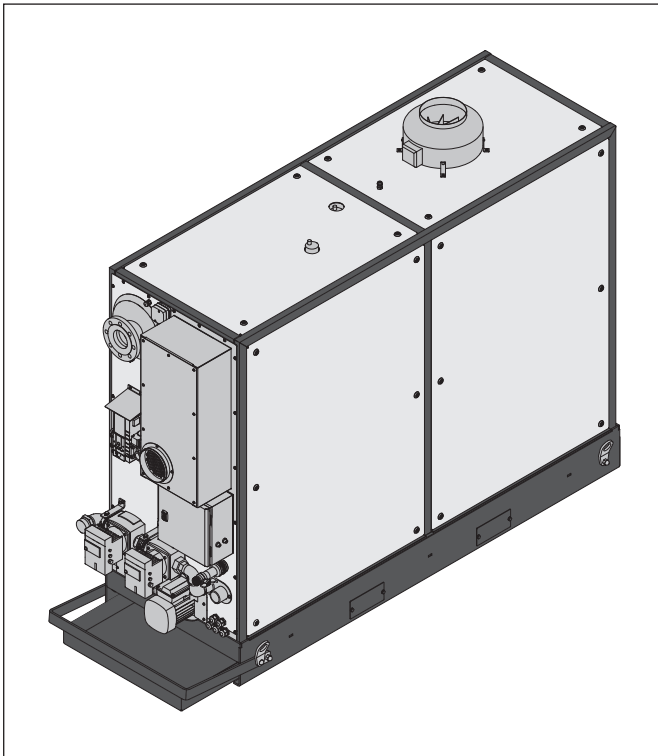

- 50.0 Standard
- 50.0 High temperature

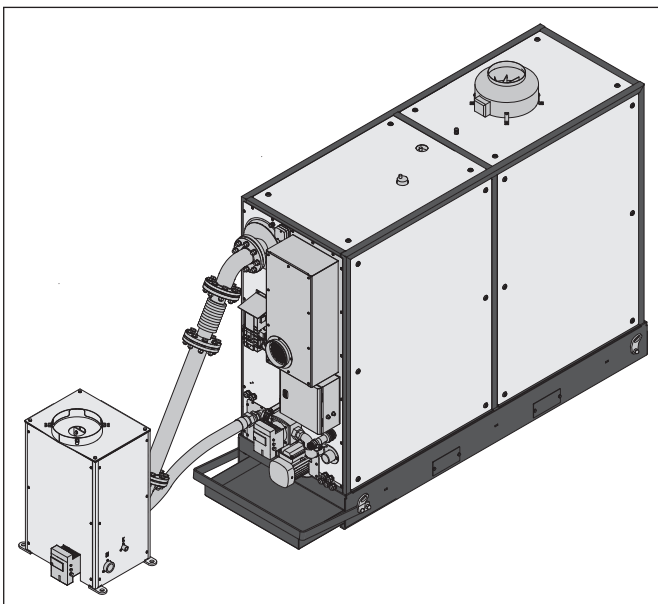

- 50.0 Calorific value

3.5 Scope of supply

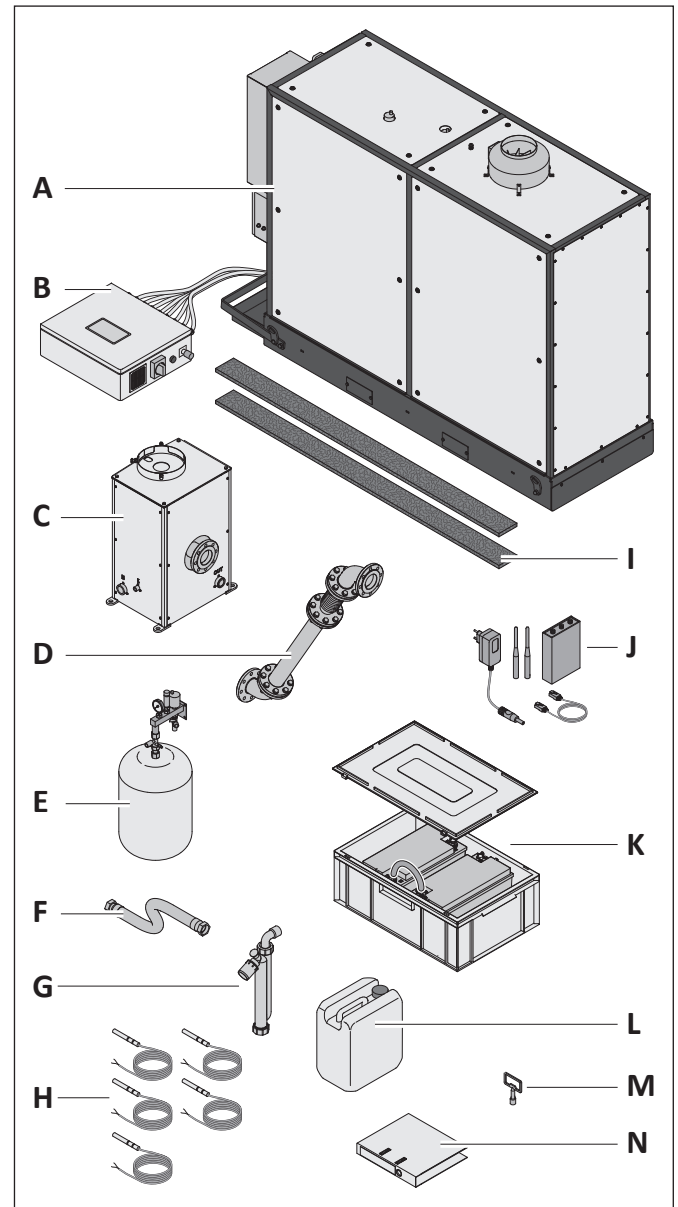

- A Generation unit
- B Control cabinet
- C Calorific value heat exchanger¹
- D Connecting pipes with axial compensator¹
- E "MAG" connection
- F Line from generation unit to calorific value heat exchanger¹
- G Siphon
- H Temperature sensor
- I Compensation strips
- J Modem²
- K Battery box with two batteries 24 V
- L Cooling medium
- M Square spanner
- N Documentation

¹ only with variant "50.0 Calorific value"

² Includes 24 months of remote monitoring (effective from commissioning; extension available subject to charge)

Product information

3.6 Product overview

3.6.1 Generation unit

The actual combined heat and power unit with the combustion engine, the alternator unit and the heat exchangers are located beneath the housing. These components are the core piece of equipment for producing the electricity and heat.

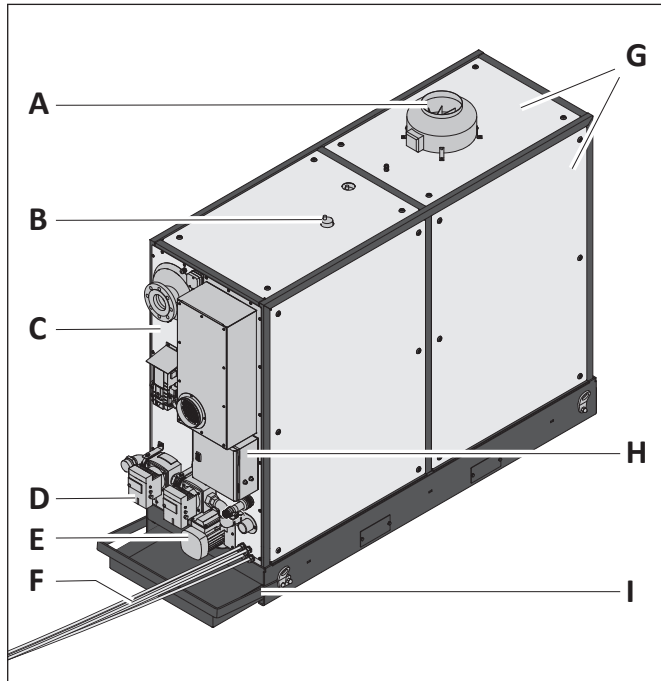

- O "Exhaust air" connection
- P Ventilation
- Q Type plate
- R Secondary pump
- S Primary pump
- T Control cabinet wiring harness
- U Housing cover
- V Connection cabinet
- W Hoop guard

Connections (50.0 Standard, 50.0 High temperature)

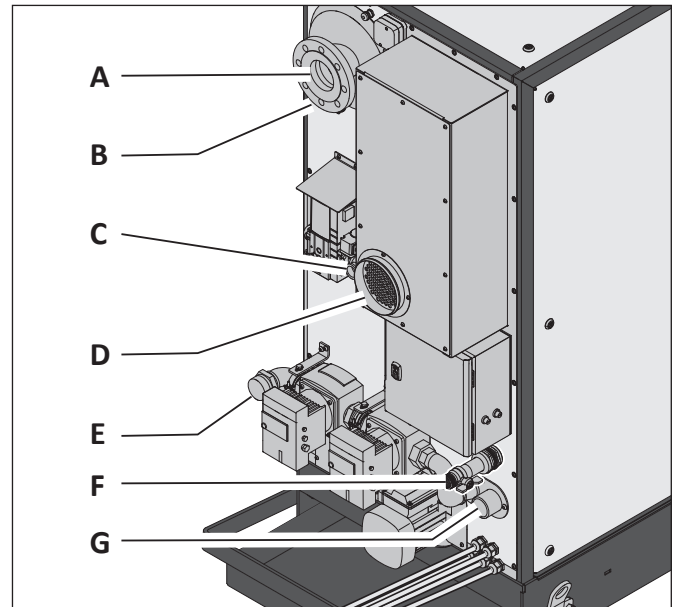

- A "Flue gas" connection
- B "Condensate" connection
- C "Gas" connection
- D "Combustion air" intake
- E "Buffer water return line" connection
- F "MAG" connection
- G "Buffer water supply line" connection

Connections (50.0 Calorific value)

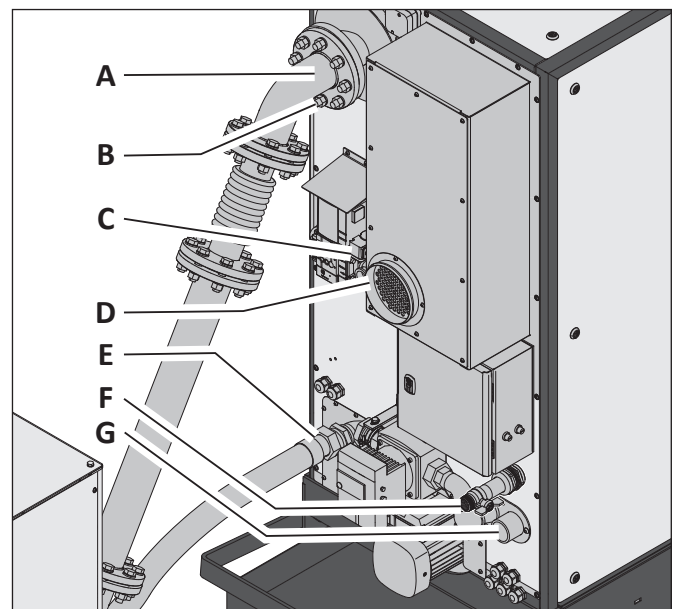

- A "Flue gas" connection
- B "Condensate" connection
- C "Gas" connection
- D "Combustion air" intake
- E "Buffer water return line" connection
- F "MAG" connection
- G "Buffer water supply line" connection

3.6.2 Control cabinet

The control cabinet contains all the components required to control the system.

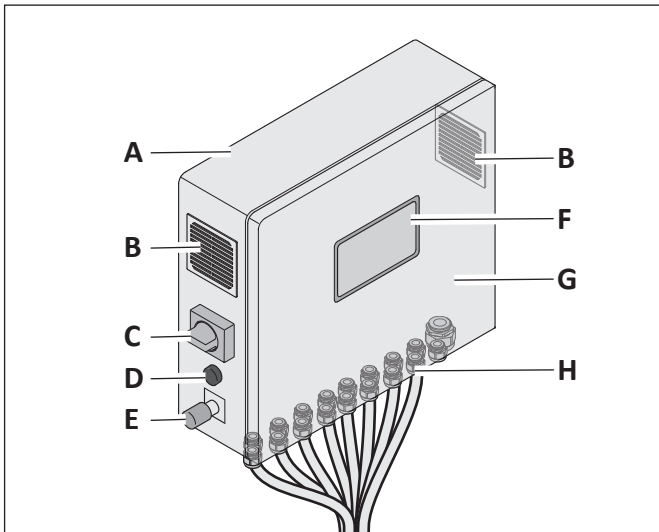

- A Housing
- B Aeration and ventilation
- C Control cabinet door
- D Emergency stop reset
- E Emergency stop switch
- F Operational display
- G Master switch
- H Cable bushings

3.6.3 Modem

The modem makes it possible to monitor the system remotely and read data via the mobile communications network.

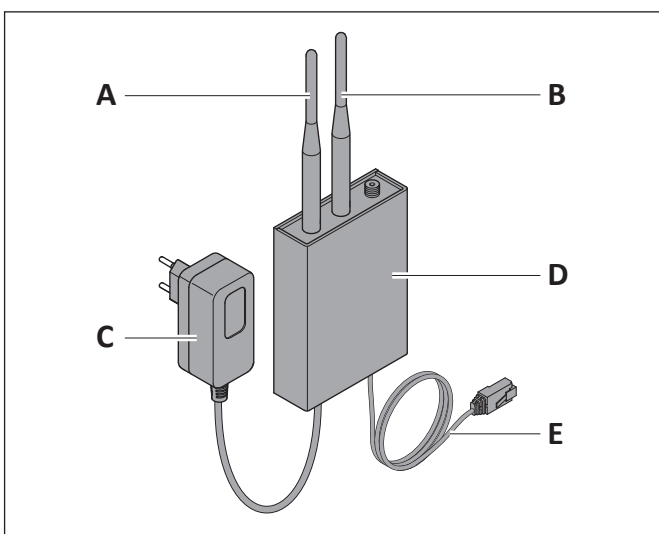

- A Antenna (slot "mobile")
- B Antenna (slot "mobile")
- C Power supply
- D LTE modem
- E Connection cable (slot "LAN 1")

3.6.4 MAG connection group

The expansion tank offsets temperature-related fluctuations in volume within the motor circuit (primary circuit).

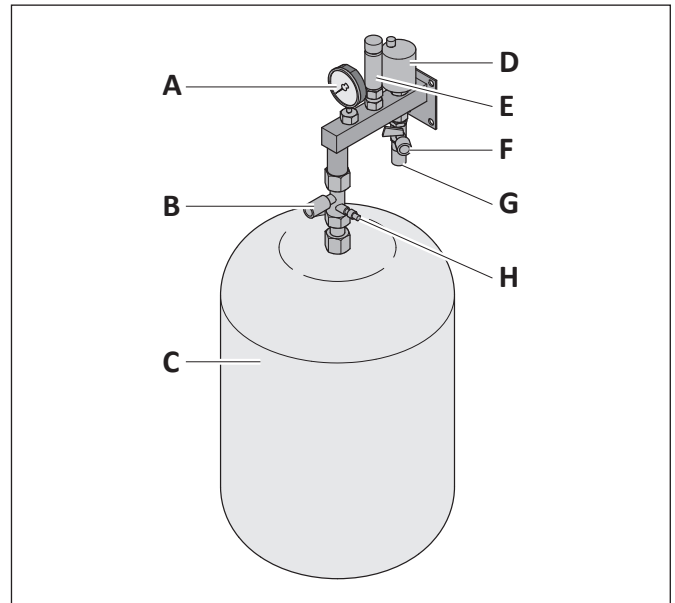

- A Manometer
- B Cap valve
- C Expansion tank
- D Self-bleeding device
- E Pressure-relief valve
- F Fill-and-drain valve (connection for replenishing cooling medium)
- G Connection to generation unit
- H Drain valve

Product information

3.6.5 Calorific value heat exchanger (only with variant “50.0 Calorific value”)

The calorific value heat exchanger uses the heat contained in the flue gas for additional heat recovery.

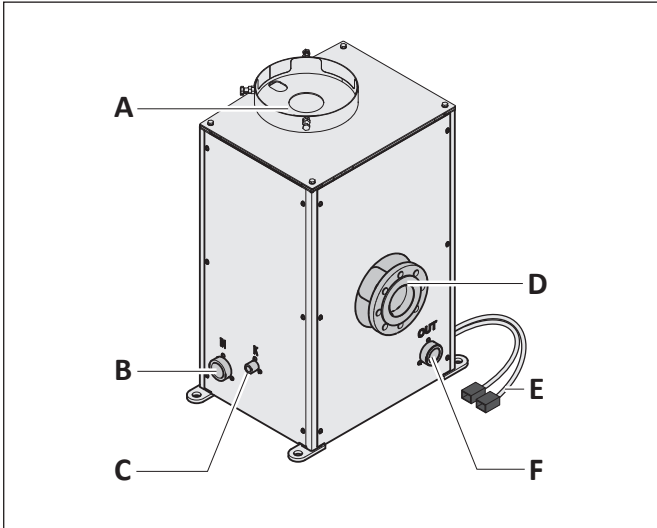

- A “Flue gas” connection (outlet)
- B “Buffer water return line” connection (inlet)
- C “Condensate” connection
- D “Flue gas” connection (inlet)
- E Connection cable for generator unit
- F “Buffer water return line” connection (outlet)

3.7 Safety devices

⚠ WARNING!

Risk of burns, pinching or electric shock!

The safety devices are intended to ensure the system is handled safely. Missing or faulty safety devices can lead to hazardous situations.

- ▶ Ensure that the protection devices are not removed.
- ▶ Follow the safety instructions on the system.
- ▶ Only remove the covers if you are required and authorised to do so.

The system is equipped with the following safety devices:

- Emergency stop switch
- Pressure-relief valve
- Protective covers
- Safety stickers

4. Storage



The system is prepared by the manufacturer for operation on delivery. The system must be put into operation within 6 months following delivery. If that is not possible, removal of the system preservative agent is necessary.

Storage of the system by the operator.
→ “2.2.2 Operator” (page 6).

⚠ ATTENTION!

Risk of damage caused by improper storage!

During long periods of downtime, lubricants and liquids settle within the system. Frost and damp conditions can damage parts of the system.

- ▶ Store the system in a frost-free, dry place.
- ▶ Arrange for the manufacturer to reapply the preservative agent if the system is to be kept out of operation for more than 12 months.

The system has been preserved by the manufacturer at the time of delivery. The preservative agent enables storage of the system for up to 12 months.

- If the system is put into operation within these 12 months:
The system can be started up in accordance with the operating manual.
- If the system is not put into operation within these 12 months:
Arrange for the manufacturer to reapply the preservative agent. The operating media must be renewed prior to commissioning.

When taking the system out of storage, the next steps must be discussed with the manufacturer.

- ▶ Contact the manufacturer.

Assembly

5. Assembly



5.1 Safety instructions for assembly

⚠ WARNING!

Hazard caused by failing to observe the assembly instructions!

Errors made when installing the system can cause serious injuries or material damage to the system or the building.

This chapter contains important information regarding the safe assembly of the system.

- ▶ Read this chapter carefully before assembling the system.
- ▶ Follow the safety instructions.
- ▶ Carry out the assembly as described.

The assembly must only be performed by trained personnel.

Electrical work must only be performed by qualified, skilled electricians.

→ “2.2.3 Trained personnel” (page 6).

- The system must be undamaged and in a faultless condition before assembly.
- Only use suitable fittings.
- Cables and lines must not be damaged, kinked or crimped.
- Before assembling, ensure that the supply voltage has been and remains disconnected. The supply voltage is only reconnected when instructed in the respective assembly step.
- The generation unit must be transported to the installation location by means of a suitable transportation device (e.g. lift truck). If it is not possible to transport it to the installation location (e.g. lack of space):
 - ▶ Contact the manufacturer.

5.2 Installation location requirements

⚠ WARNING!

Risk of suffocation, gas explosions or material damage caused by incorrectly installing the system!

Failing to observe these requirements can lead to hazardous situations when handling electricity, gas or hot water.

This chapter contains important information for preventing hazardous situations.

- ▶ Ensure that all of the installation location requirements are complied with.

5.2.1 Overview of the installation location

To operate the system, some equipment must be provided on site. The following illustration shows examples of the required components.

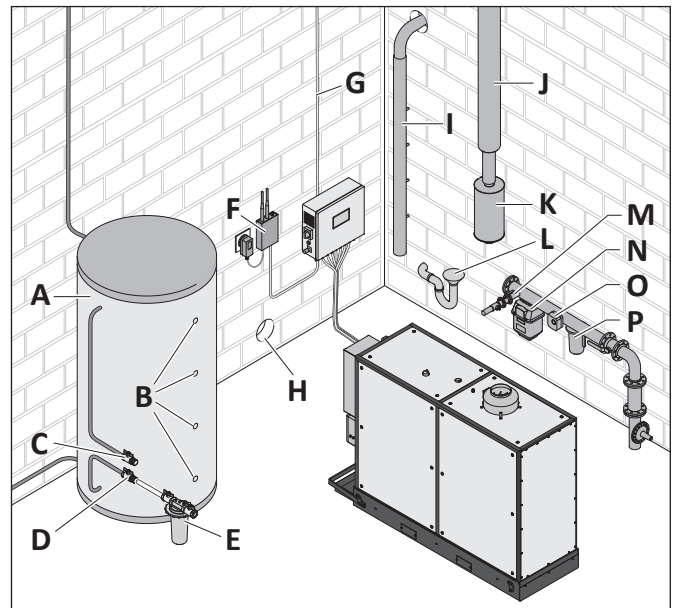

- A Buffer tank
- B Temperature sensor holding fixture
- C Buffer water supply line
- D Buffer water return line
- E KMS filter
- F Modem
- G Supply voltage
- H Supply air opening
- I Exhaust air duct
- J Flue gas routing
- K Flue gas silencer
- L Condensate drain
- M Gas supply
- N Gas meter
- O Gas flow monitor
- P Gas filter

The heating system also includes the peak load boiler and pipework system that connects the system via the buffer tank.

The associated documents must be observed for the specific installation situation.

- 📄 Planning and installation instructions for flue gas/exhaust air

5.2.2 Installation room

The installation room must meet the following requirements:

- The installation room must comply with the effective applicable laws and regulations (e.g. in Germany, the ordinance for heat-producing appliances (Feuerstättenverordnung)).
- The substrate on which the generation unit is to be installed must be flat, even, solid, dry and load-bearing.
- The minimum ambient temperature is +5 °C. If the ambient temperature exceeds +30 °C, the system regulates downwards, at +37 °C the system switches off. The efficiency reduces as the temperature increases.
- The system must be protected against frost and the elements.

The following are not permitted:

- Installation on floating screed.
- Operation of tumble dryers in the same room.
- Storage of explosive or highly flammable materials (e.g. paper, paints, petrol) within the installation location.
- Use of aggressive substances (e.g. sprays, solvents, chlorinated cleaning agents, paints, adhesives) in the vicinity of the system.

If the system is installed in vaulted cellars or bare smooth-walled rooms (hard-walled), there is a risk of noise and sound resonance.

The system must be positioned so that the following requirements are fulfilled:

- None of the system's ventilation or extraction devices may be blocked or closed.
- The emergency stop switch must always be accessible.

Space requirement (50.0 Standard, 50.0 High temperature)

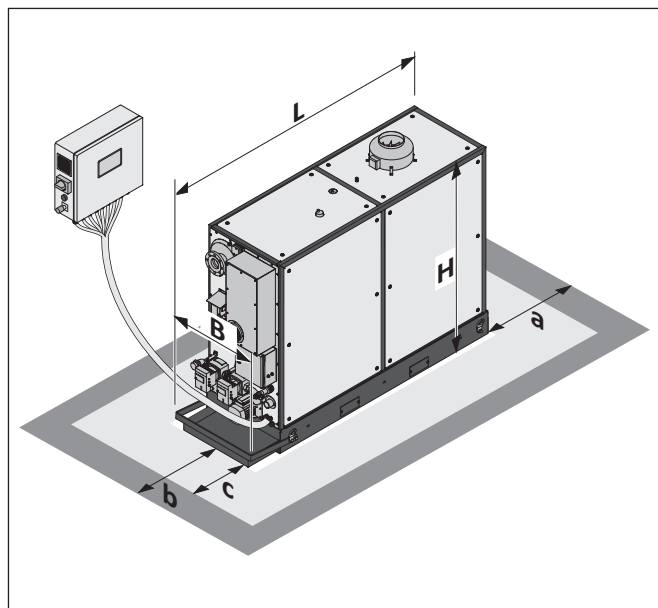

L	Length (including hoop guard)	2,587 mm
B	Width (including hoop guard)	800 mm
H	Height	1,959 mm
a	Distance from the generation unit – Minimum free space required to the front	> 1,000 mm
b	Distance from the generation unit – Minimum free space required to the side and rear	> 700 mm
c	Distance from the generation unit – Free space after clarification and approval by the manufacturer	< 700 mm

Assembly

Space requirement (50.0 Calorific value)

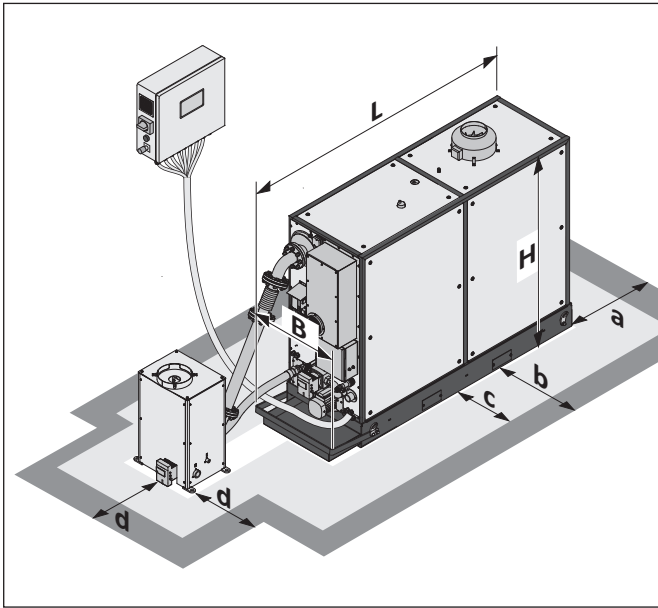

L	Length (including hoop guard)	2,531 mm
B	Width (including hoop guard)	800 mm
H	Height	1,961 mm
a	Distance from the generation unit – Minimum free space required to the front	> 1,000 mm
b	Distance from the generation unit – Minimum free space required to the side and rear	> 700 mm
c	Distance from the generation unit – Free space after clarification and approval by the manufacturer	< 700 mm
d	Distance from the calorific value heat exchanger – Minimum free space required	> 500 mm

All systems – minimum distance for maintenance work:

- 500 mm free space above the system.
- 300 mm free space next to the control cabinet.

If the minimum distances are not maintained:

- ▶ Contact the manufacturer.

5.2.3 Heating system

The structural elements of the building's heating system primarily comprise the peak load boiler, the buffer tank, and the pipework system and radiators.

The peak load boiler supplies the required residual heat if the heating energy requirement exceeds the capacity of the system (e.g. in extremely cold weather).

For the system to operate, a buffer tank is required, which must comply with the following requirements:

- The buffer tank must have holding fixtures for the temperature sensors.
- The buffer tank must have shut-off devices fitted on the connections to the system.
- The buffer tank must be designed to meet the system specifications:
minimum 50 litres per kW thermal for installations > 10 kW_{th}

These specifications are technical minimum conditions. Regional or national funding guidelines may differ and must be checked.

The dimensioning of the pipework system must be designed to meet the following requirements:

- Maximum heat requirement of the building.
- Maximum thermal capacity of the system.

5.2.4 Flue gas routing

For the system to operate, the building must have an exhaust system, which must comply with the following requirements:

- The local laws and regulations must be complied with (e.g. in Germany, the building regulations).
- The flue gas routing must comply with the local regulations (e.g. in Germany, DIN 18160).
- For systems made of plastic (e.g. in Germany according to DIN EN 14471) or metal (e.g. in Germany according to DIN EN 1856-1, 2) - depending on the planning results - pressure classes of at least 200 Pa up to a maximum of 1500 Pa must be satisfied (e.g. in Germany according to DIN EN 13384-2 at least pressure class P1 up to a maximum of pressure class M1).
- The exhaust system must be marked with an exhaust gas line sticker indicating the pressure class (e.g. in Germany according to DIN V 18160).
- The flue gases must be removed via a flue.
- As a fundamental rule, the flue must extract the flue gases via the roof.
- The dimensions for the flue gas ducting and flue must be calculated on an individual basis.
- The gradient of the horizontal section must be min. 5 cm per metre.
- The flue must be inspected and approved for operation (e.g. by a master chimney sweep).
- A flue gas silencer must be fitted in the flue gas routing. The flue gas silencer (optionally available) must be installed near the generation unit.
- The flue gas routing must have a water-filled siphon at its lowest point.
- A carbon monoxide sensor can be additionally used on site.

5.2.5 Exhaust air duct

⚠ WARNING!

Risk of suffocation due to improper use of exhaust air!

The exhaust air must not be used for heating purposes. Poisonous gases may be produced inside the generation unit that can lead to death by suffocation.

- ▶ Ensure that the exhaust air from the generation unit is guided outside.
- ▶ Make sure that the exhaust air and flue gas are always extracted separately to each other.
- ▶ Ensure that the supply air is not contaminated by the exhaust air.

Additional devices with exhaust air (e.g. washer-dryers) may only be installed subject to consultation with a suitable specialist or chimney sweep.

5.2.6 Supply air supply

Sufficient supply air must be supplied for the combustion process and the ambient temperature:

- The total requirement of the heating system (e.g. for the peak load boiler) must be born in mind.
- The supply air supply must meet the system specification.
- 📄 Technical data.
- The supply air must not be supplied via a concentric pipe if the inner pipe is used for flue gas routing.
- If the ambient temperature in the installation room is permanently above 30 °C, additional air exchange is required.

5.2.7 Gas supply

For the system to operate, a gas supply is required that must comply with the following requirements:

- The gas supply must comply with the established regulations (e.g. in Germany, TRGI).
- The system specifications (e.g. type and composition of the gas) must be complied with.
- 📄 Technical data.
- The building's system must be fitted with a gas flow monitor, gas meter and a gas filter.
- The gas flow monitor must meet the system specifications.
- 📄 Technical data.
- Connection via a gas appliance outlet is never permitted.

5.2.8 Water supply

⚠ ATTENTION!

Risk of damage caused by poor water quality!

Too high a proportion of suspended solids and magnetite along with the incorrect water hardness can damage the generation unit or shorten its service life.

- ▶ Check the water quality regularly.
- The water quality must comply with the specifications of the applicable standards and Directives (e.g. in Germany, VDI Regulation 2035).
- The heating system water must be free from mechanical impurities.
- The hardness of the water must be < 1 °dH.
- Conductivity < 100 µS/cm.
- PH value > 8.2 and < 9.0.

5.2.9 Condensate drain

For the system to operate, the building must have a condensate drain, which must comply with the following requirements:

- The condensate drain must be depressurised.
- The inner diameter of the condensate drain must not be reduced.
- A neutralization device is recommended for each system to collect condensate containing oil.
- The siphon must be made of corrosion-resistant, acid-resistant material (e.g. plastic or stainless steel).
- The siphon must be regularly filled with water to prevent it from drying out.
- The siphon must also be filled with water during an interruption of operation.
- The local water disposal regulations must be considered.

5.2.10 Power supply

For the system to operate, the building requires a connection to the electricity supply that must comply with the following requirements:

- The specifications and technical connection conditions of the energy provider must be taken into consideration (e.g. electricity meter).
- The start-up power and cable lengths must be taken into account when calculating the cable cross-sections.
- A clockwise rotating field must be present.
- The supply voltage must meet the system specifications.

 Technical data.

5.2.11 Remote monitoring

Remote monitoring via the modem requires access to the mobile communications network. The modem must be accessible. The position of the modem has an influence on the reception quality.

The reception quality may be improved as required by means of the following accessory (optionally available):

- External antenna (distance max. 15 m)
- Patch cable (max. 100 m long)

A socket must be available on site for the power supply to the modem, which is separate to the system and control cabinet.

5.3 Assembly steps

Brief overview:

- 5.3.1 Preparing for assembly
- 5.3.2 Unpacking the system
- 5.3.3 Positioning the generation unit
- 5.3.4 Screwing the control cabinet in position
- 5.3.5 Screwing the expansion tank connection block in position
- 5.3.6 Connecting the generation unit (50.0 Standard, 50.0 High temperature)
- 5.3.7 Connecting the generation unit (50.0 Calorific value)
- 5.3.8 Connecting the temperature sensors
- 5.3.9 Connecting the modem
- 5.3.10 Connecting the battery
- 5.3.11 Connecting the control cabinet
- 5.3.12 Checking the connections

5.3.1 Preparing for assembly

- ▶ Familiarise yourself with the assembly situation and the documentation.
 - System
 - System components
 - Safety devices
 - Accessories
 - Installation location
 - Operation manual and supporting documents
- ▶ Gather together the required tools and materials.
- ▶ Keep the assembly area clear of objects than may get in the way or be damaged.
- ▶ Check that all of the installation location requirements have been fulfilled.
 - “5.2 Installation location requirements” (page 14).
- ▶ Ensure that the supply voltage has been and remains disconnected. Only connect the supply voltage when instructed in the respective assembly step.

If accessories (e.g. flue gas silencer, exhaust air kit) are required for the assembly process:

- ▶ Ensure that the accessory is correctly assembled and ready for connection.
- ▶ Ensure that the lines from the accessories have been laid correctly and are accessible.

 Manuals for accessories.

5.3.2 Unpacking the system

⚠ ATTENTION!

Risk of damage caused by improper handling!

The system may be damaged during unpacking or transportation.

- ▶ Do not cut through the protective packaging.
- ▶ Keep objects that might damage the system away from it (e.g. tools).

- ▶ Remove the packaging material from the system.
- ▶ Remove the parts included in the scope of delivery from on top of the generation unit.
- ▶ Check the system and all the parts it contains for damage.
- ▶ Check the scope of delivery according to the delivery note for completeness.

If parts are missing or damaged:

- ▶ Contact the manufacturer.
- ▶ Remove the packaging material from the installation location.
 - "11.1 Disposing of packaging" (page 36).

5.3.3 Positioning the generation unit

⚠ ATTENTION!

Risk of damage to the generation unit caused by improper transportation!

In narrow transportation routes, it may be necessary to disassemble parts of the generation unit in order to move the device into the installation location. Disassembly for transport may only be carried out by the manufacturer.

- ▶ Contact the manufacturer.

- ▶ Select a suitable installation location.
 - "5.2 Installation location requirements" (page 14).

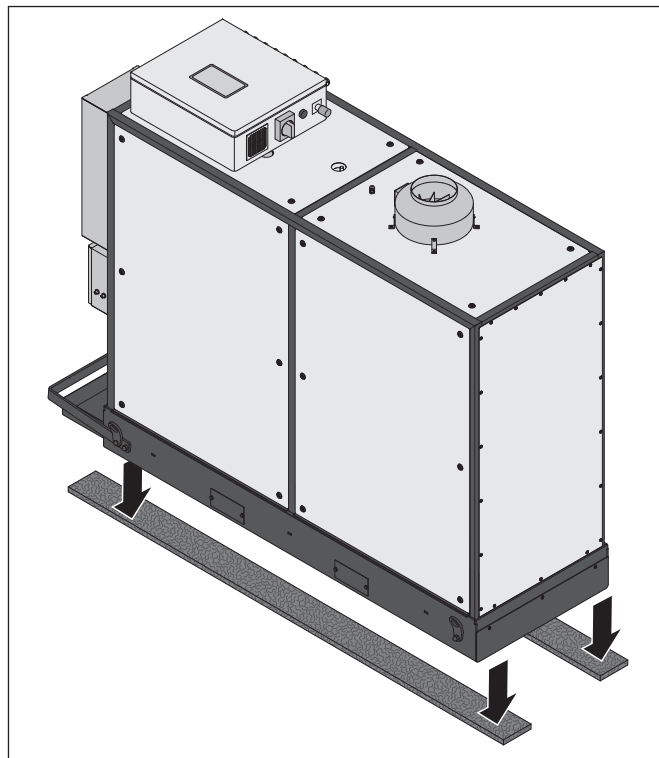

- ▶ Position the compensation strips.
- ▶ Place the generation unit on the compensation strips.
- ▶ Ensure that the generation unit stands level.

5.3.4 Screwing the control cabinet in position

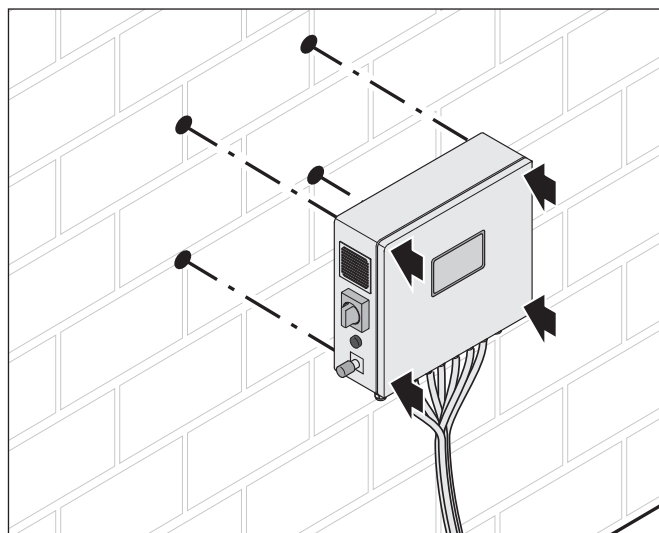

- ▶ Open the control cabinet.
- ▶ Mark the drill hole positions on the wall.
- ▶ Drill the holes for the screws.
- ▶ Screw the control cabinet onto the wall.
- ▶ Observe the minimum distances.
 - "5.2.2 Installation room" (page 15).

Assembly

5.3.5 Screwing the expansion tank connection block in position

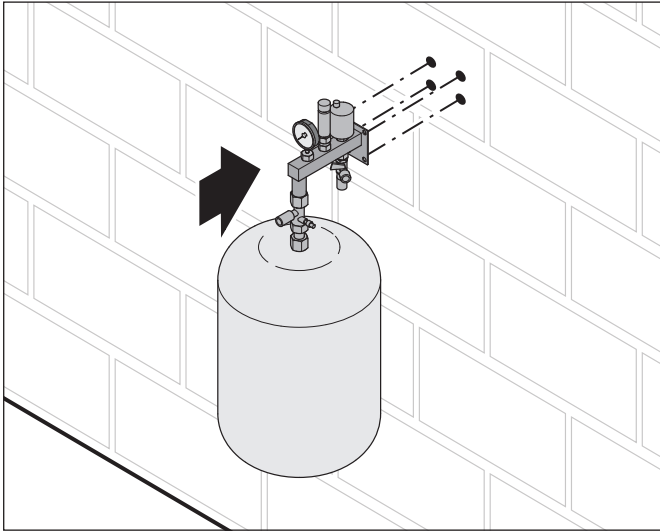

- ▶ Mark the drill hole positions on the wall.
- ▶ Drill the holes for the screws.
- ▶ Screw the expansion tank connection block onto the wall.

5.3.6 Connecting the generation unit (50.0 Standard, 50.0 High temperature)

When connecting the system to the heating system it is necessary to follow the appropriate hydraulic diagram.
 → “12.2 Hydraulic diagrams” (page 37).

Always match the connections to the identifiers on the generation unit.

Pay attention the to connection sizes and type when connecting the lines.

Generation unit connection sizes

Connection	Connection size and type
Buffer water return line	2" male thread
Buffer water supply line	2" male thread
MAG	3/4" male thread
Condensate	3/4" male thread
Flue gas – in front of silencer	DN 80
Flue gas – after silencer	DN 100
Exhaust air	DN 200
Gas	1" female thread

⚠ ATTENTION!

Risk of damage caused by improper connection of lines!

Fixed supply lines will transfer vibrations to the building. Vibrations may damage the supply lines.

- ▶ Only use flexible lines for all the lines connected to the generation unit.
- ▶ Pay close attention when matching the lines and connections.

Buffer water return line

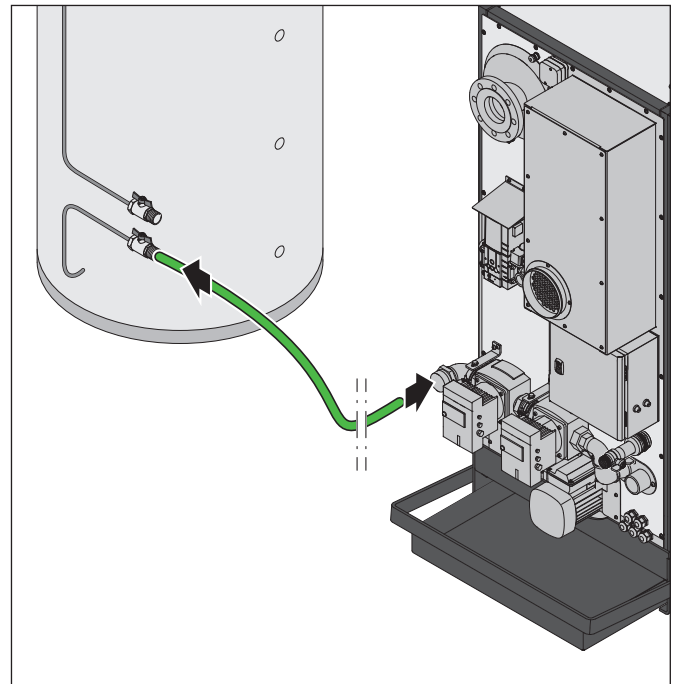

- ▶ Connect the line to the return line of the buffer tank.
- ▶ Connect the line to the “Buffer water return line” connection on the generation unit.

Buffer water supply line

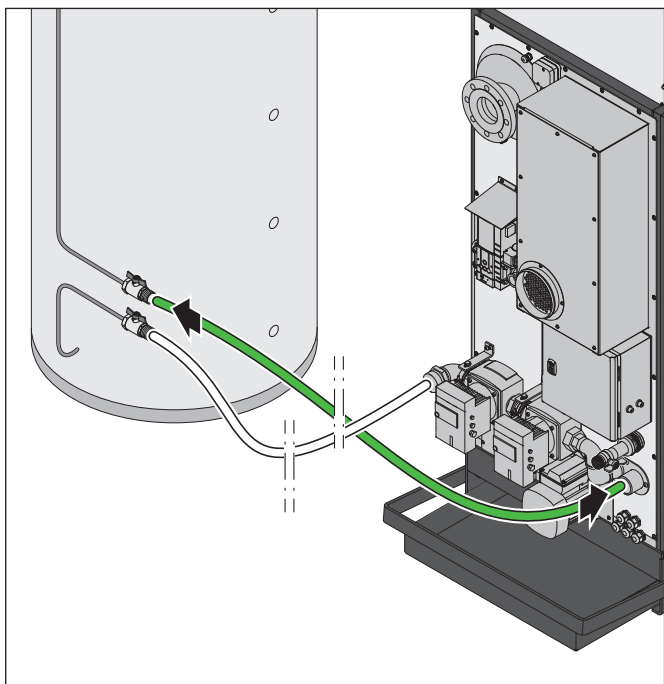

- ▶ Connect the line to the supply line of the buffer tank.
- ▶ Connect the line to the "Buffer water supply line" connection on the generation unit.

MAG

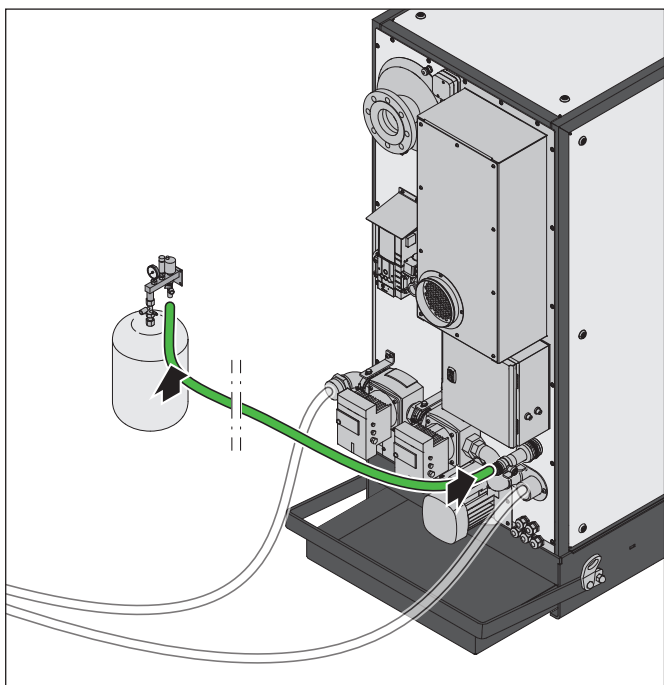

- ▶ Before connecting, make sure that the pre-pressure of the MAG connection group is 1.0 bar cold.
- ▶ Connect the cable to the "MAG" connection on the generating unit.
- ▶ Connect the cable to the MAG connection group.

Condensate

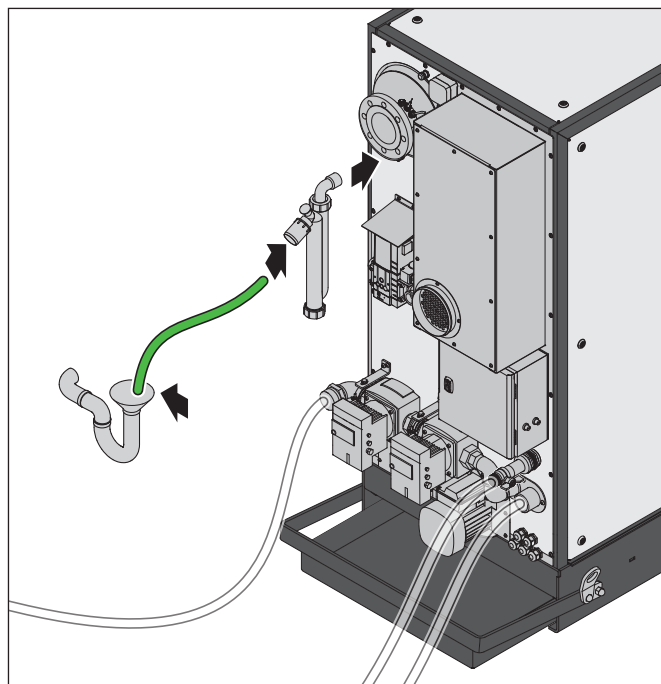

The line for the condensate water must be corrosion resistant.

The line must have a sufficient gradient between the generation unit and the drain.

- ▶ Connect the siphon to the "Condensate" connection on the generation unit.
- ▶ Connect the line to the siphon.
- ▶ Connect the line to the condensate drain.

Assembly

Flue gas

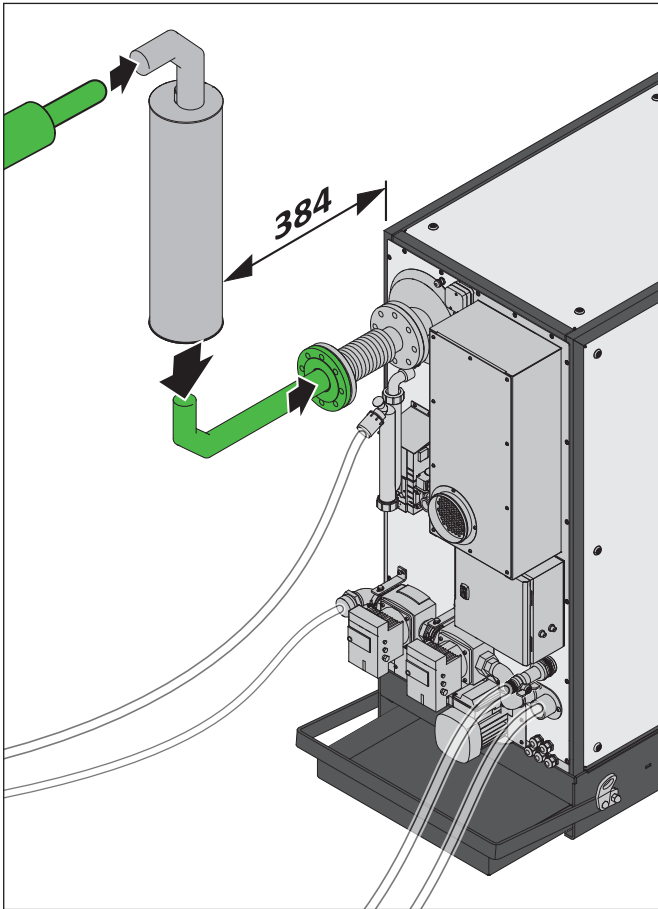

The line must be laid with a sufficient gradient to the generation unit.

- ▶ Make sure that a suitable flue gas silencer (optionally available) is present:
 - In the flue gas routing.
 - In close proximity to the generation unit.
 - With horizontal installation with correct discharge of the condensate water.
- ▶ Connect the axial expansion joint (optionally available) to the “flue gas” connection of the generation unit. Alternatively, a hose compensator (optionally available) can also be used.
- ▶ Connect the line to the axial compensator.
- ▶ Connect the line to the flue gas silencer on both sides.
- ▶ Fasten the line.
- ▶ Ensure that the line is not interrupted (e.g. that it does not slip out of vertically installed parts).
- ▶ Ensure that the connection piece (optionally available) cannot vibrate out of place.

📄 Flue gas silencer instructions.

➔ www.rmbenergie.com

Exhaust air

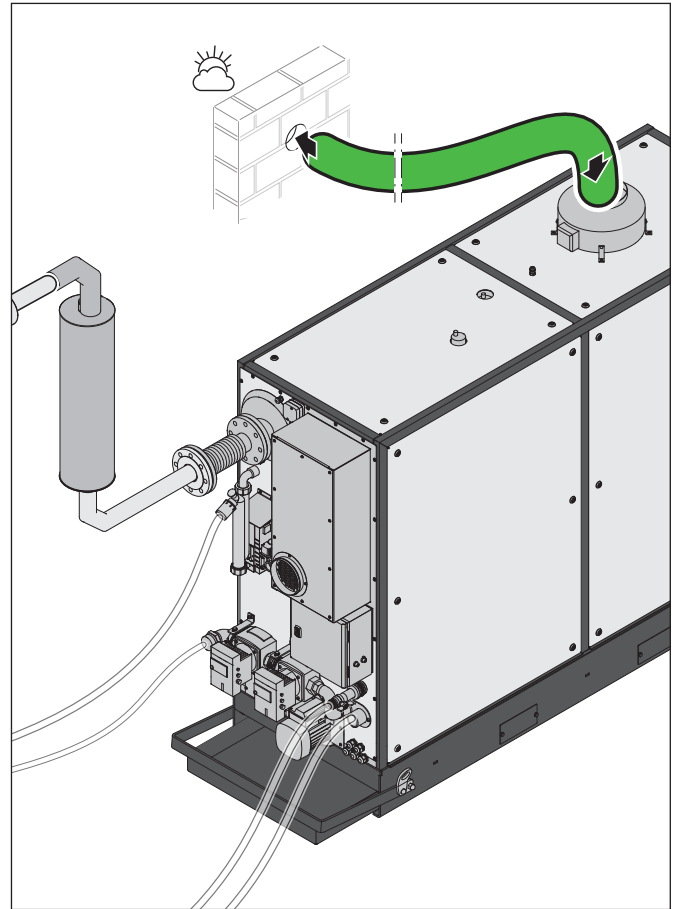

The line (e.g. flexible aluminium tube) must be flexibly connected and removable for maintenance work.

- ▶ Connect the line to the “exhaust air” connection on the generation unit.
- ▶ Guide the line outside.
- ▶ Secure the line.
- ▶ Ensure that when the exhaust air duct is connected, the system remains protected against frost and the elements.

Gas

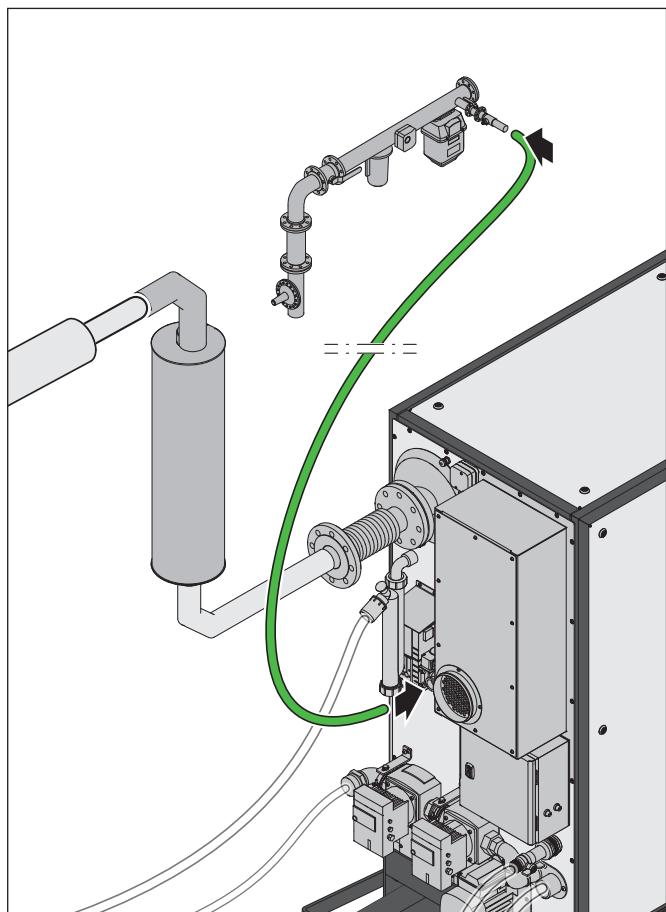

The gas supply must comply with the established regulations (e.g. in Germany, TRGI). Connection via a gas appliance outlet is not permitted.

- ▶ Connect the line to the “gas” connection on the generation unit.
- ▶ Connect the line to the connection on the gas supply.

5.3.7 Connecting the generation unit (50.0 Calorific value)

When connecting the system to the heating system it is necessary to follow the appropriate hydraulic diagram. → “12.2 Hydraulic diagrams” (page 37).

Always match the connections to the identifiers on the generation unit.

Pay attention the to connection sizes and type when connecting the lines.

Generation unit connection sizes

Connection	Connection size and type
Buffer water return line	2” male thread
Buffer water supply line	2” male thread
MAG	3/4” male thread
Condensate	3/4” male thread
Flue gas – in front of silencer	DN 80
Flue gas – after silencer	DN 100
Exhaust air	DN 200
Gas	1” female thread

Calorific value heat exchanger connection sizes

Connection	Connection size and type
Buffer water return line to the generation unit	2” male thread
Buffer water return line to the buffer tank	2” male thread
MAG	3/4” male thread
Condensate	3/4” male thread
Flue gas – to the generation unit	DN 80
Flue gas – in front of silencer	DN 80
Flue gas – after silencer	DN 100

Assembly

⚠ ATTENTION!

Risk of damage caused by improper connection of lines!

Fixed supply lines will transfer vibrations to the building. Vibrations may damage the supply lines.

- ▶ Only use flexible lines for all the lines connected to the generation unit.
- ▶ Pay close attention when matching the lines and connections.

Buffer water return line

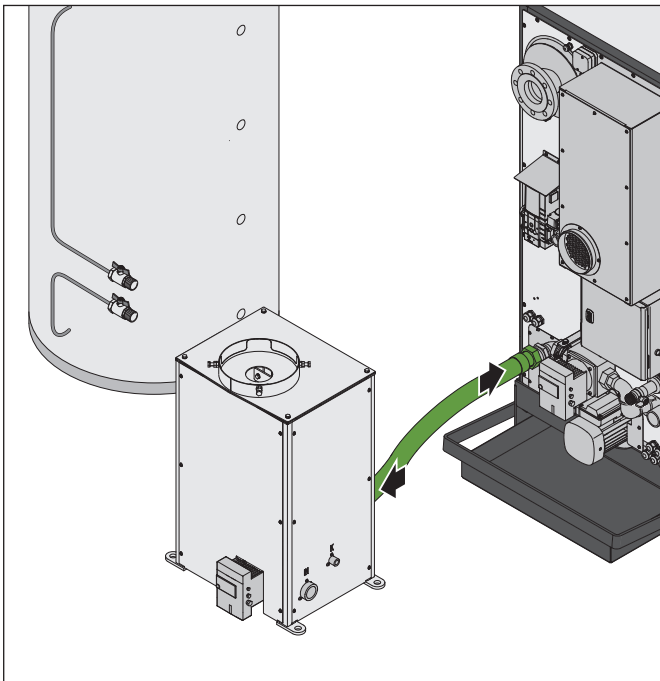

- ▶ Connect the line to the “Buffer water return line” connection on the generation unit.
- ▶ Connect the line to the “Buffer water return line” connection (inlet) on the calorific value heat exchanger.

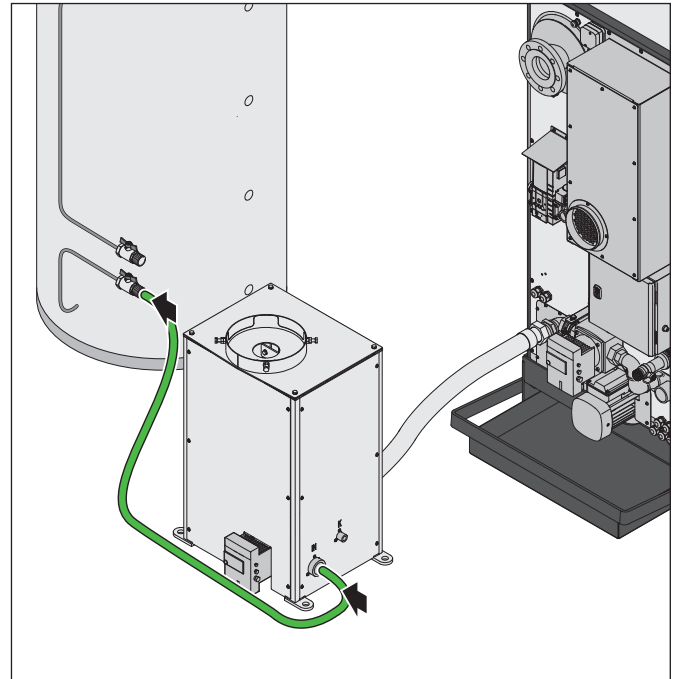

- ▶ Connect the line to the return line of the buffer tank.
- ▶ Connect the line to the “Buffer water return line” connection (inlet) on the calorific value heat exchanger.

Buffer water supply line

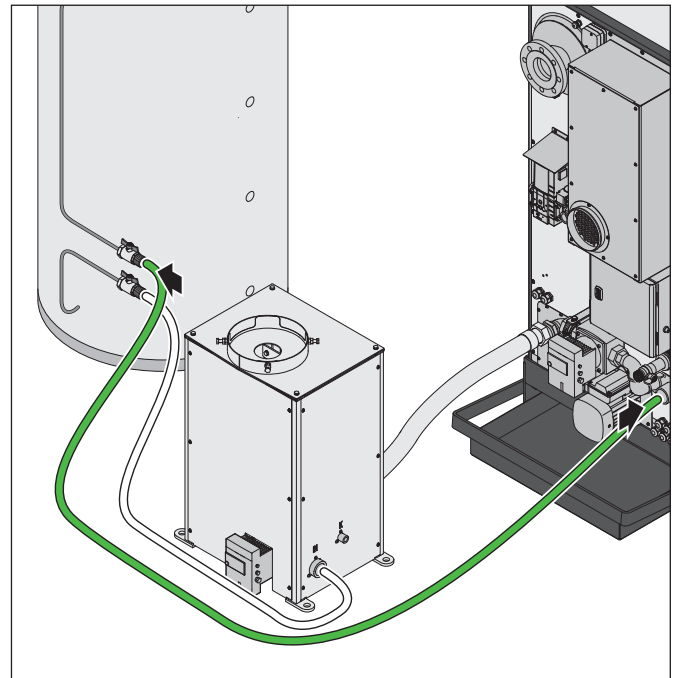

- ▶ Connect the line to the supply line of the buffer tank.
- ▶ Connect the line to the “Buffer water supply line” connection on the generation unit.

MAG

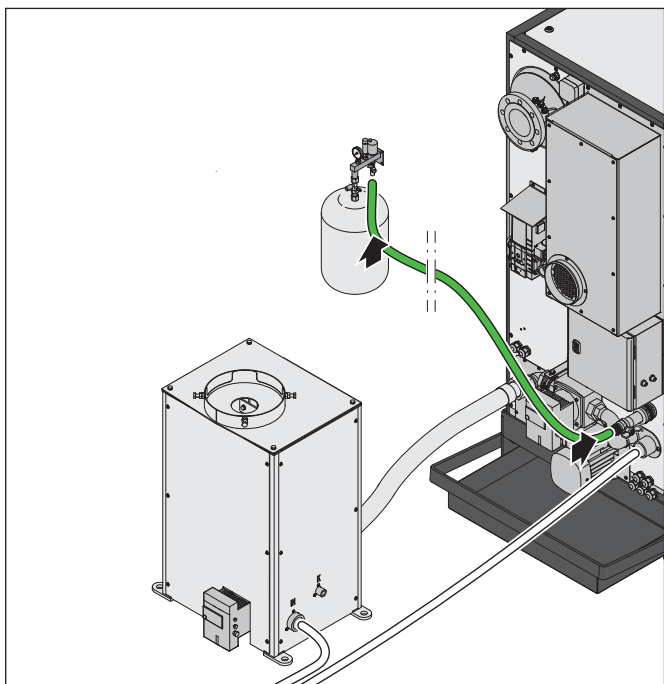

- ▶ Before connecting, ensure that the system pressure of the expansion tank connection block is 1.0 bar when cold.
- ▶ Connect the line to the “expansion tank” connection on the generation unit.
- ▶ Connect the line to the expansion tank connection block.

Condensate

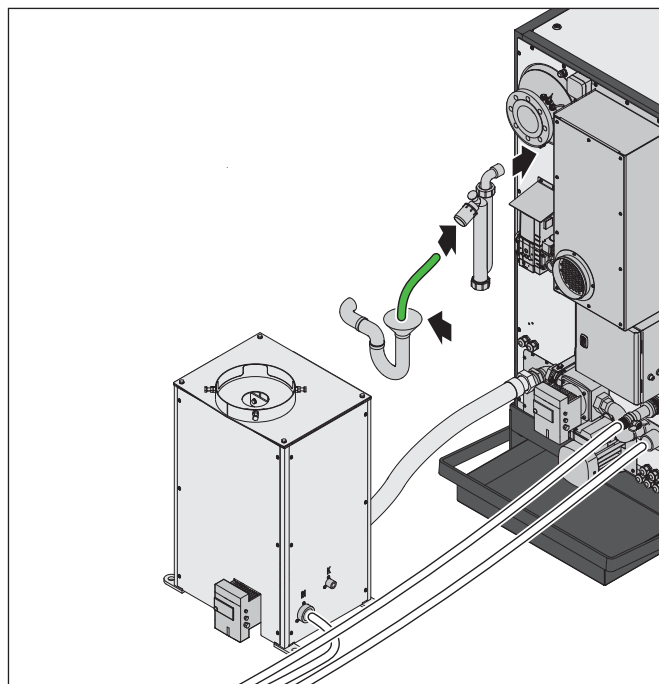

The line for the condensate water must be corrosion resistant. The line must have a sufficient gradient between the generation unit and the drain.

- ▶ Connect the line to the “Condensate” connection on the generation unit.
- ▶ Connect the line to the condensate drain.

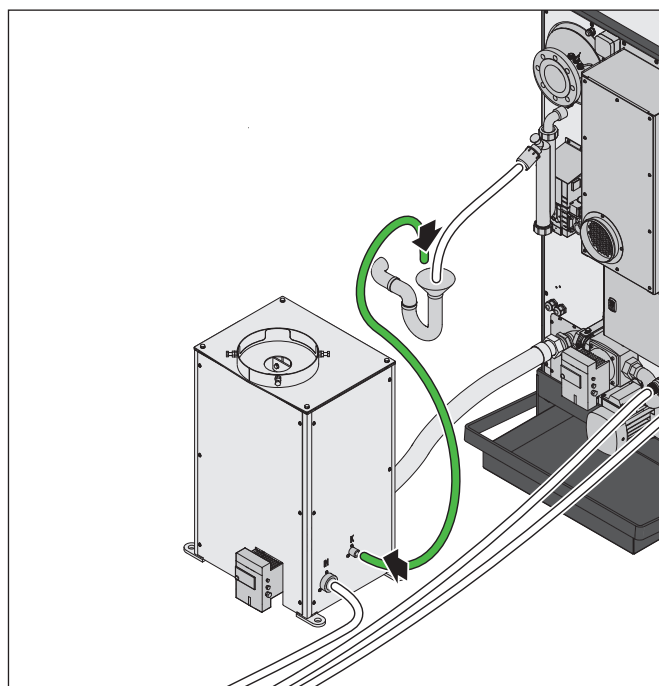

The line for the condensate water must be corrosion resistant. The line must have a sufficient gradient between the calorific value heat exchanger and the drain.

- ▶ Connect the line to the “condensate” connection on the calorific value heat exchanger.
- ▶ Connect the line to the condensate drain.

Assembly

Flue gas

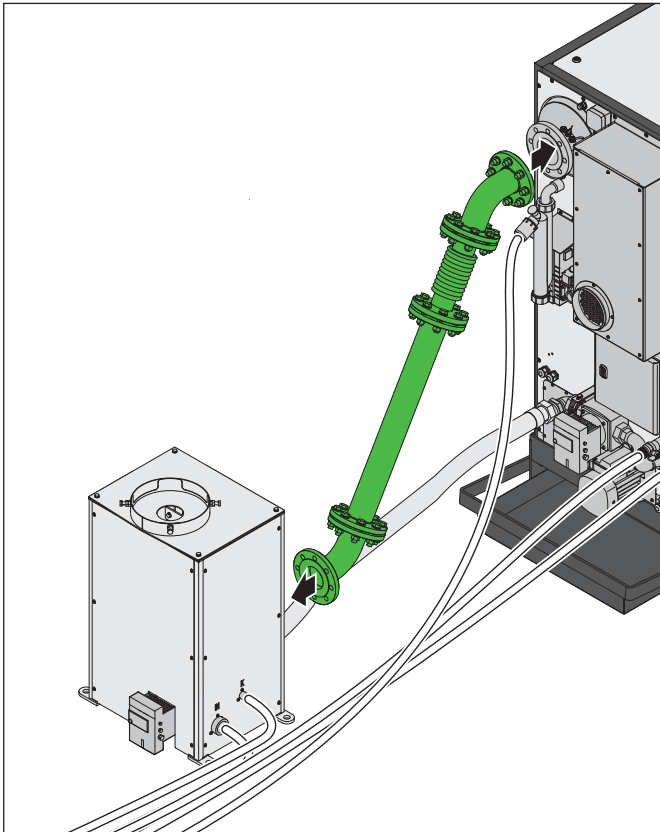

- ▶ Connect the connection pipes with the axial compensator to the “flue gas” connection of the generation unit.
- ▶ Connect the connection pipes to the “flue gas” connection (inlet) of the calorific value heat exchanger.
- ▶ Fasten the connecting pipes.
- ▶ Ensure that the line is not interrupted (e.g. that it does not slip out of vertically installed parts).
- ▶ Ensure that the connection piece (optionally available) cannot vibrate out of place.

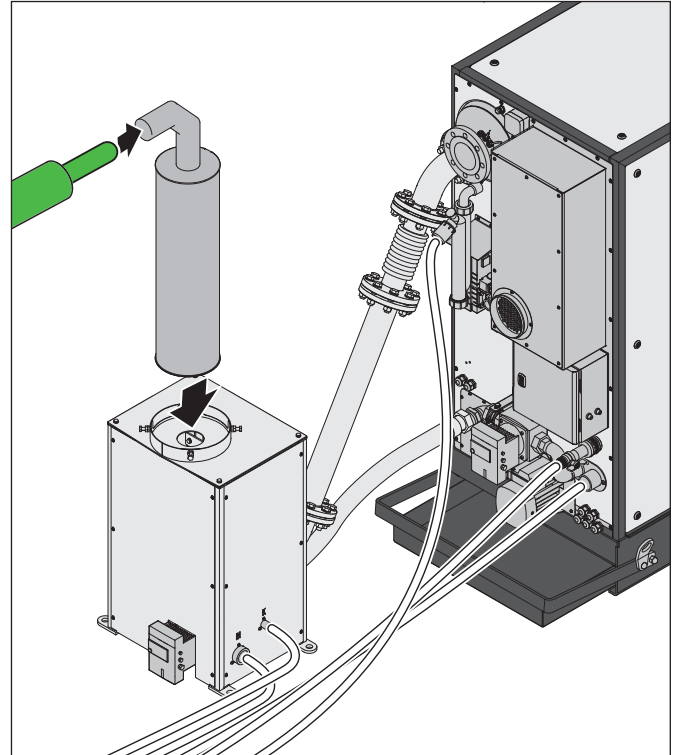

The line must be laid with a sufficient gradient to the calorific value heat exchanger.

- ▶ Make sure that a suitable flue gas silencer (optionally available) is present:
 - In the flue gas routing.
 - In close proximity to the generation unit.
 - With horizontal installation with correct discharge of the condensate water.
- ▶ Connect the line to the “flue gas” connection (outlet) on the calorific value heat exchanger.
- ▶ Connect the line to the flue.
- ▶ Ensure that the line is not interrupted (e.g. that it does not slip out of vertically installed parts).
- ▶ Ensure that the connection piece (optionally available) cannot vibrate out of place.

Electricity

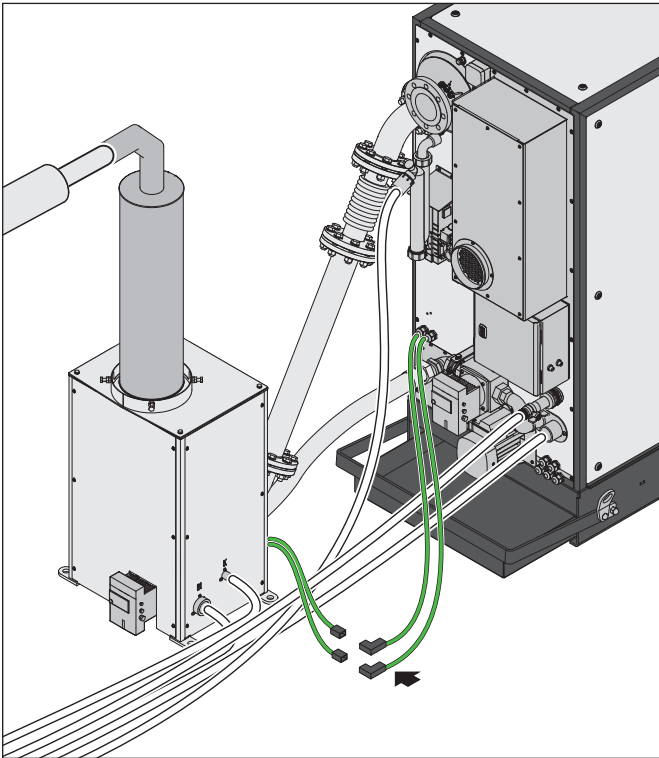

- ▶ Connect the cable from the calorific value heat exchanger to the generation unit.

Exhaust air

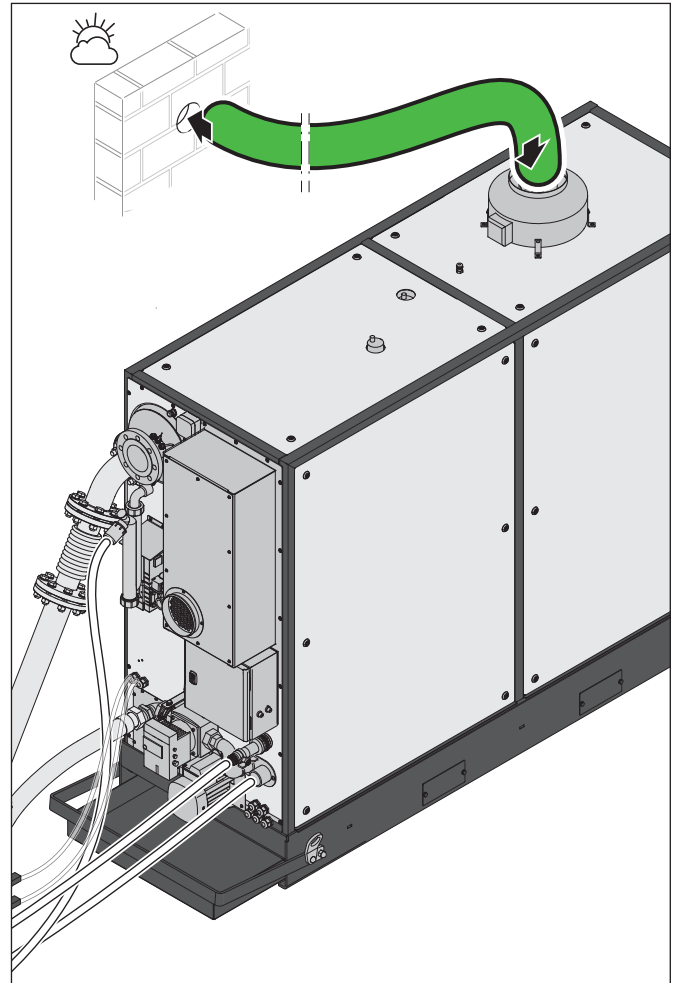

The line (e.g. flexible aluminium tube) must be flexibly connected and removable for maintenance work.

- ▶ Connect the line to the “exhaust air” connection on the generation unit.
- ▶ Guide the line outside.
- ▶ Secure the line.
- ▶ Ensure that when the exhaust air duct is connected, the system remains protected against frost and the elements (e.g. by using a ventilation grill with movable fins).

Assembly

Gas

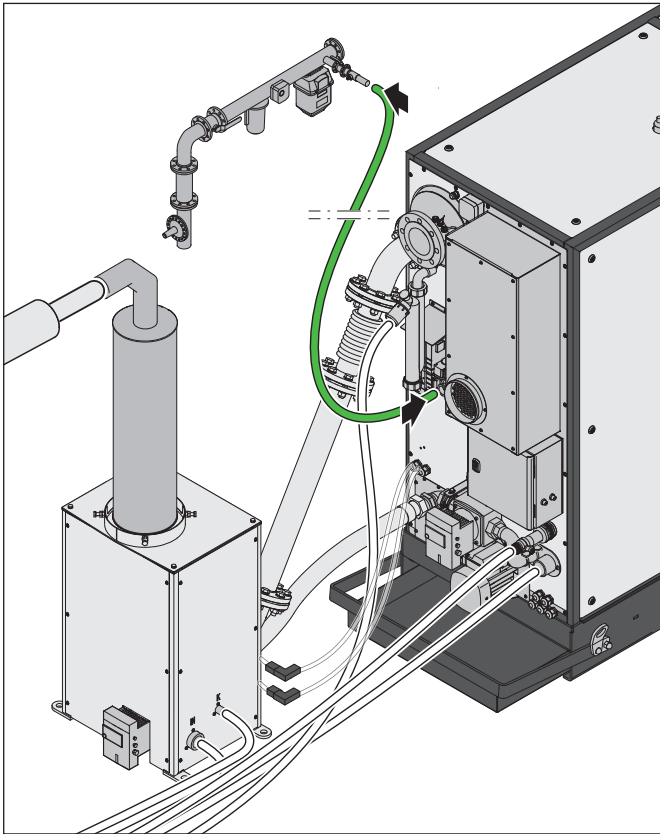

The gas supply must comply with the established regulations (e.g. in Germany, TRGI). Connection via a gas appliance outlet is not permitted.

- ▶ Connect the line to the “gas” connection on the generation unit.
- ▶ Connect the line to the connection on the gas supply.

5.3.8 Connecting the temperature sensors

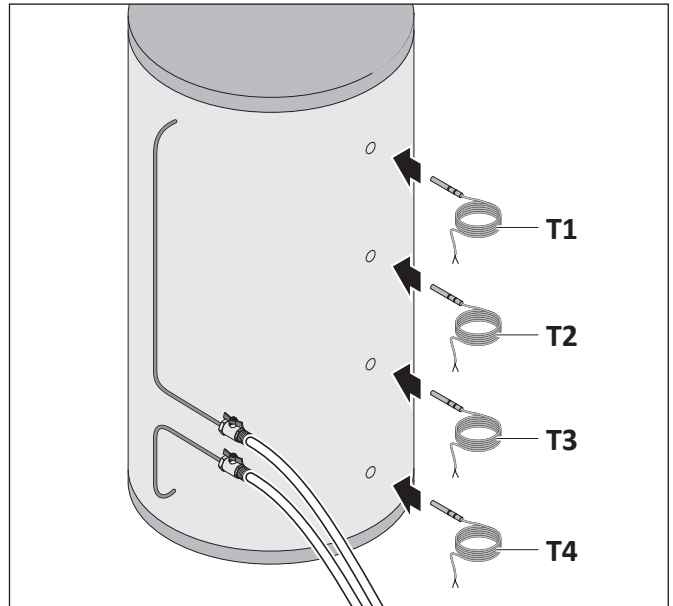

- ▶ Attach four temperature sensors (T1-T4) to the buffer tank. When attaching, bear in mind the number of buffer tanks.
→ “12.2 Hydraulic diagrams” (page 37).
- ▶ Connect the temperature sensor (T5) as a strategy sensor to the supply line of the heating circuit or the existing switch.
→ “12.2 Hydraulic diagrams” (page 37).
- ▶ Guide the cables from the temperature sensors (T1-T5) to the control cabinet.

Observe the associated wiring diagrams for the electrical connection.

- 📄 Wiring diagrams (on the inside of the control cabinet door).

5.3.9 Connecting the modem

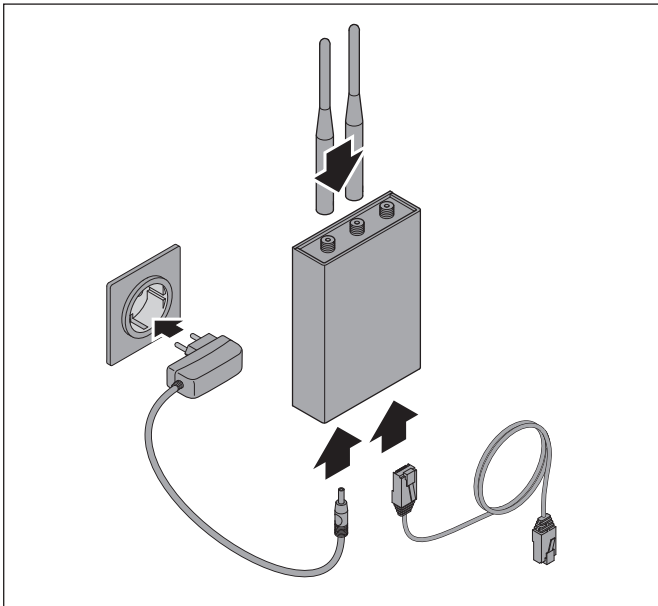

When connecting the modem, the following points must be observed:

- If the modem is subjected to high temperatures, it may not function properly.
 - The length of the connection cable between the control cabinet and the modem must not exceed 100 m.
- Fit the modem such that reception is guaranteed.
- Use a socket for the power supply to the modem, which is separate to the system and control cabinet.
- 📄 Modem manual.

5.3.10 Connecting the battery

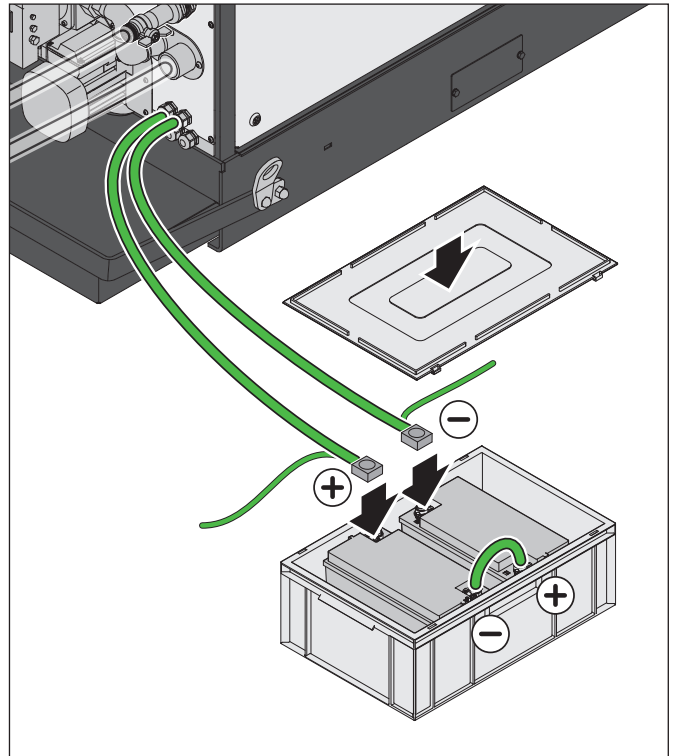

The batteries are located in the battery box.

- Connect the batteries to the generation unit.

Assembly

5.3.11 Connecting the control cabinet

⚠ WARNING!

Risk of injury from electric shock!

The cables must be deenergised during assembly.

- ▶ Deenergise the cables.
- ▶ Ensure that the cables remain deenergised during installation.

⚠ ATTENTION!

Risk of damage caused by the incorrect matching of connectors!

Having the wrong polarity on the connection terminals can seriously damage the control mechanism.

- ▶ Pay attention to the correct polarity on the connection terminals and to a right-rotating field.

All cables must be fed into the control cabinet through the cable connections from underneath.

Use the enclosed wiring diagrams to identify the connection terminals.

- 📄 Wiring diagrams (on the inside of the control cabinet door).

Please refer to the technical data for the permissible cross-sectional areas of the supply lines.

- 📄 Technical data.

It is necessary to observe the valid regulations (e.g. in Germany the VDE directives).

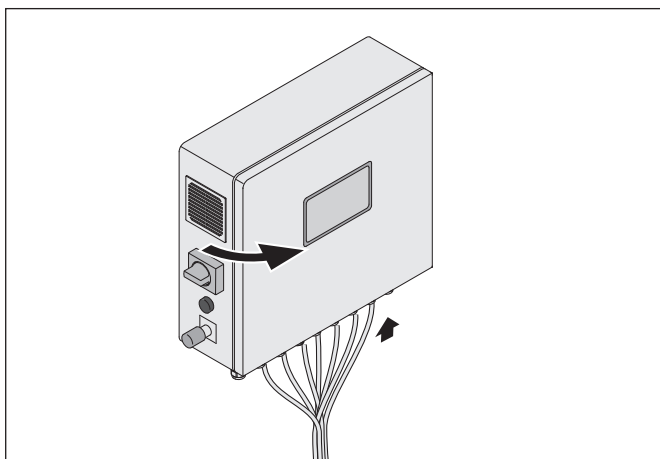

- ▶ Open the control cabinet.
- ▶ Connect the temperature sensors (T1-T5).
- ▶ Connect the modem.
- ▶ Connect the batteries.

The connection of additional components depends on the heating system.

→ “12.2 Hydraulic diagrams” (page 37).

- ▶ Connect any additional components (e.g. peak load boiler, equipment of the building control technology) to the control mechanism.

Once all components have been connected:

- ▶ Make sure that the mains connection is de-energised.
- ▶ Connect the supply voltage to the control cabinet.
- ▶ Close the control cabinet.

5.3.12 Checking the connections

Once the assembly process is complete, the following points must be checked:

- Leak-tightness of all lines.
 - Flexibility of all lines to the generation unit.
 - Tight fit of all connections in the control cabinet.
 - No damage, kinks or pinches in the cabling and lines.
 - The siphon of the condensate drain is filled with water.
 - Tension-free installation of all lines to the generation unit.
 - Clockwise rotating field.
- ▶ Check the system.

If the exhaust air and flue gas are extracted together:

- ▶ Ensure that the system is fitted with a suitable exhaust air kit.

If the exhaust air or flue gas is extracted in combination with another heat source (peak load boiler or another system):

- ▶ Ensure that the system is fitted with a suitable backflow preventer.

Following assembly, the commissioning of the system can be arranged with the manufacturer.

- 📄 Commissioning request.

Download forms:

➔ www.rmbenergie.com

- ▶ Arrange a time and date for the commissioning.

6. Commissioning



⚠ WARNING!

Hazard caused by improperly assembling the system!

Improperly installed systems can cause serious injuries or material damage to the system or the building.

- ▶ Ensure that the system is installed in accordance with the regulations and that the commissioning can be carried out.

The system must be inspected by the manufacturer (or a specialist partner authorised by the manufacturer) in accordance with the specifications of the commissioning certificate.

Once the inspection has been passed, the system will be released for permanent operation

If the system fails the inspection, the manufacturer will take appropriate measures, e.g. the manufacturer can request a repair.

⚠ ATTENTION!

Danger of damage due to downtime!

During long periods of downtime, lubricants and liquids settle within the system.

- ▶ Ensure that the system is not subjected to downtimes exceeding 3 months in length.
- ▶ After a downtime period of no longer than 3 months, start the system for at least 120 minutes.
- ▶ If system downtime continues beyond this time, restart the system every 4 weeks and run for at least 120 minutes.

After commissioning, the system must be started up at regular intervals.

Downtimes must not exceed a maximum period of 3 months.

If operation is not possible for a period in excess of 3 months, preservative agent must be applied to the system by the manufacturer.

The system can be programmed to perform a regular start (e.g. 1x weekly for at least 1 hour). Programming the time program is described in the accompanying manual.

7. Operating



⚠ ATTENTION!

Hazard caused by failing to observe the operating instructions!

This chapter contains important information regarding the safe operation of the system. Incorrect settings in the control mechanism can damage the system or shorten its service life.

- ▶ Read this chapter carefully before operating the system.
- ▶ Follow the safety instructions.

Only the manufacturer and specialist partner authorised by the manufacturer have access to the “Experts” area of the “RMB/Control” control mechanism.

→ “2.2.1 Manufacturer” (page 6).

Only qualified personnel trained by the manufacturer have access to the “Specialist” area of the “RMB/Control” control mechanism.

→ “2.2.3 Trained personnel” (page 6).

Trained users have access to the non-protected areas of the “RMB/Control” control mechanism, but not to the “Experts” and “Specialist” areas.

The system must only be operated by qualified users.

→ “2.2.4 User” (page 6).

The “RMB/Control” control mechanism regulates and monitors the system. The system is operated via the operational display on the control cabinet.

Its operation is described in the accompanying manual.

📄 “RMB/Control” operating manual.

8. Cleaning



⚠ WARNING!

Risk of burns when cleaning hot system components!

This chapter contains important information regarding the correct way to clean the system. The parts of the system that can become very hot (e.g. flue gas routing) must not be cleaned while the system is in operation.

- ▶ Read this chapter carefully before cleaning the system.
- ▶ Do not clean any hot components.
- ▶ Follow the safety instructions.

The system must only be cleaned by qualified users.
→ “2.2.4 User” (page 6).

⚠ ATTENTION!

Risk of damage caused by cleaning agents!

Sprays, solvents and chlorinated cleaning agents can cause corrosion and changes in properties.

- ▶ Only use suitable cleaning agents.

At least once a year:

- ▶ Clean the system with a damp cloth.

In the case of heavier soiling:

- ▶ Clean the system with warm water and a neutral, non-abrasive cleaning agent.

If work that creates considerable dust has been performed in the installation location (e.g. drilling, abrasive cutting):

- ▶ First switch off the system.
- ▶ Clean the air filter in the generation unit.
- ▶ Clean the ventilation system in the control cabinet.

For questions about cleaning:

- ▶ Contact the manufacturer.

Service repairs

9. Service repairs



9.1 Maintenance

⚠ WARNING!

Risk of injuries caused by faulty safety components!

This chapter contains important information regarding the safe maintenance of the system. Important safety components may fail or suffer a fault as a result of insufficient maintenance.

- ▶ Read this chapter carefully before performing maintenance work.
- ▶ Wait for the system to cool down before carrying out maintenance.
- ▶ Perform the maintenance according to the specified intervals.

Maintenance work must only be performed by trained personnel.

Electrical work must only be performed by qualified, skilled electricians.

→ “2.2.3 Trained personnel” (page 6).

The system will indicate the pending maintenance 300 hours before the maintenance interval expires. If the maintenance is not performed, the system will run for another 200 hours at minimum capacity after the interval has expired.

After the 200 hours have passed, the system will switch off.

The system can only be put back into operation once the maintenance has been performed.

The maintenance must be performed and documented according to the points in the maintenance log.

📄 Maintenance plan.

Specific tasks for maintaining the system are only performed by the manufacturer.

→ “2.2.1 Manufacturer” (page 6).

In the case of specific tasks for maintaining the system:

- ▶ Contact the manufacturer.
- 📄 Maintenance manual.

9.2 Fault resolution

⚠ WARNING!

Hazard caused by failing to observe the error messages!

Malfunctions indicate faults with the system or incorrect settings in the control mechanism. Malfunctions must be rectified immediately to prevent further subsequent damage.

- ▶ Rectify all faults immediately.

System malfunctions are displayed by the control mechanism in the operational display.

📄 “RMB/Control” operating manual.

In the case of malfunctions that cannot be resolved using the control mechanism:

- ▶ Initiate remote maintenance.
- ▶ Follow the manufacturer’s instructions.

9.3 Repair

⚠ WARNING!

Risk of injuries caused by faulty components!

This chapter contains important information regarding the safe repair of the system.

Defective components can cause additional subsequent damage to the system.

- ▶ Read this chapter carefully before performing repairs on the system.
- ▶ Defective components must be replaced promptly.
- ▶ The system must be taken out of operation until any safety-related parts have been replaced.
- ▶ Wait for the system to cool down before replacing any components.
- ▶ Only use components approved by the manufacturer.

Repair work must only be performed by trained personnel.

Electrical work must only be performed by qualified, skilled electricians.

→ “2.2.3 Trained personnel” (page 6).

- ▶ Switch off the system.
- 📄 Operation manual “RMB/Control”.
- ▶ Switch off the master switch.
- ▶ Replace any faulty components.

10. Disassembly

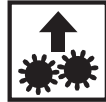

⚠ WARNING!

Hazard caused by failing to observe the disassembly instructions!

This chapter contains important information regarding the correct way to disassemble the system. Failing to observe such information can lead to severe injuries.

- ▶ Read this chapter carefully before disassembling the system.
- ▶ Follow the safety instructions.
- ▶ Wait for the system to cool down before disassembling it.
- ▶ Ensure that the cables are deenergised.
- ▶ Ensure that the cables remain deenergised during the work.

The disassembly must only be performed by trained personnel.

Electrical work must only be performed by qualified, skilled electricians.

→ “2.2.3 Trained personnel” (page 6).

- ▶ Switch off the system.
- ▶  “RMB/Control” operating manual.

- ▶ Close all valves in the system.
- ▶ Close all valves in the heating system.
- ▶ Remove all cables from the control cabinet that are not connected to the generation unit.
- ▶ Remove the lines from the generation unit:
 - Buffer supply line
 - Buffer return line
 - Gas
 - Batteries
 - MAG
 - Condensate
 - Flue gas
 - Exhaust air
- ▶ Remove the cable from the MAG connection group.
- ▶ Unscrew the MAG connection group.
- ▶ Remove the lines from the calorific value heat exchanger ¹:
 - Buffer return line
 - Condensate
 - Flue gas

¹ only with variant “50.0 Calorific value”

Disposal

11. Disposal



11.1 Disposing of packaging

⚠ ATTENTION!

Risk of environmental damage caused by failing to dispose of the packaging in the proper manner!

- ▶ Do not dispose of the packaging in the normal domestic waste.
 - ▶ Send the packaging to the appropriate environmental recycling facility.
-

The packaging is used to protect the system against transportation damage.

The packaging materials have been selected from an environmentally sustainable perspective and are produced from recyclable materials. The packaging materials can be put back into the raw materials cycle after use. This will save valuable resources.

- ▶ Separate the packaging according to material and dispose of it in an environmentally friendly manner.



11.2 Disposing of the system

⚠ ATTENTION!

Risk of environmental damage caused by failing to dispose of the system in the proper manner!

- ▶ Do not dispose of the system in the normal domestic waste.
 - ▶ Send the system to the appropriate environmental recycling facility.
-

The disposal must only be performed by trained personnel.

→ “2.2.3 Trained personnel” (page 6).

- ▶ Dispose of the system in accordance with the statutory requirements via a specialist waste management company or your municipal disposal facility.



12. Appendix



12.1 Technical data

Technical data can be found in the corresponding system documentation.

📄 System documentation.

Further information and technical data:

➔ www.rmbenergie.com

12.2 Hydraulic diagrams

The following hydraulic diagrams illustrate examples for connecting the system to the heating system. These hydraulic diagrams do not replace the need to correctly design the technical aspects heating system.

📄 The hydraulic diagram applicable to the heating system must be checked for correctness and completeness.

The installation location requirements must be observed. In particular:

- The building's heating system.
 - "5.2.3 Heating system" (page 16).
- Water quality.
 - "5.2.8 Water supply" (page 17).

Further hydraulic plans:

➔ www.rmbenergie.com

Appendix

12.2.1 Heating system variant 1 – 1 CHP, 1 buffer tank, peak load boiler connected to buffer tank via hydraulic separator

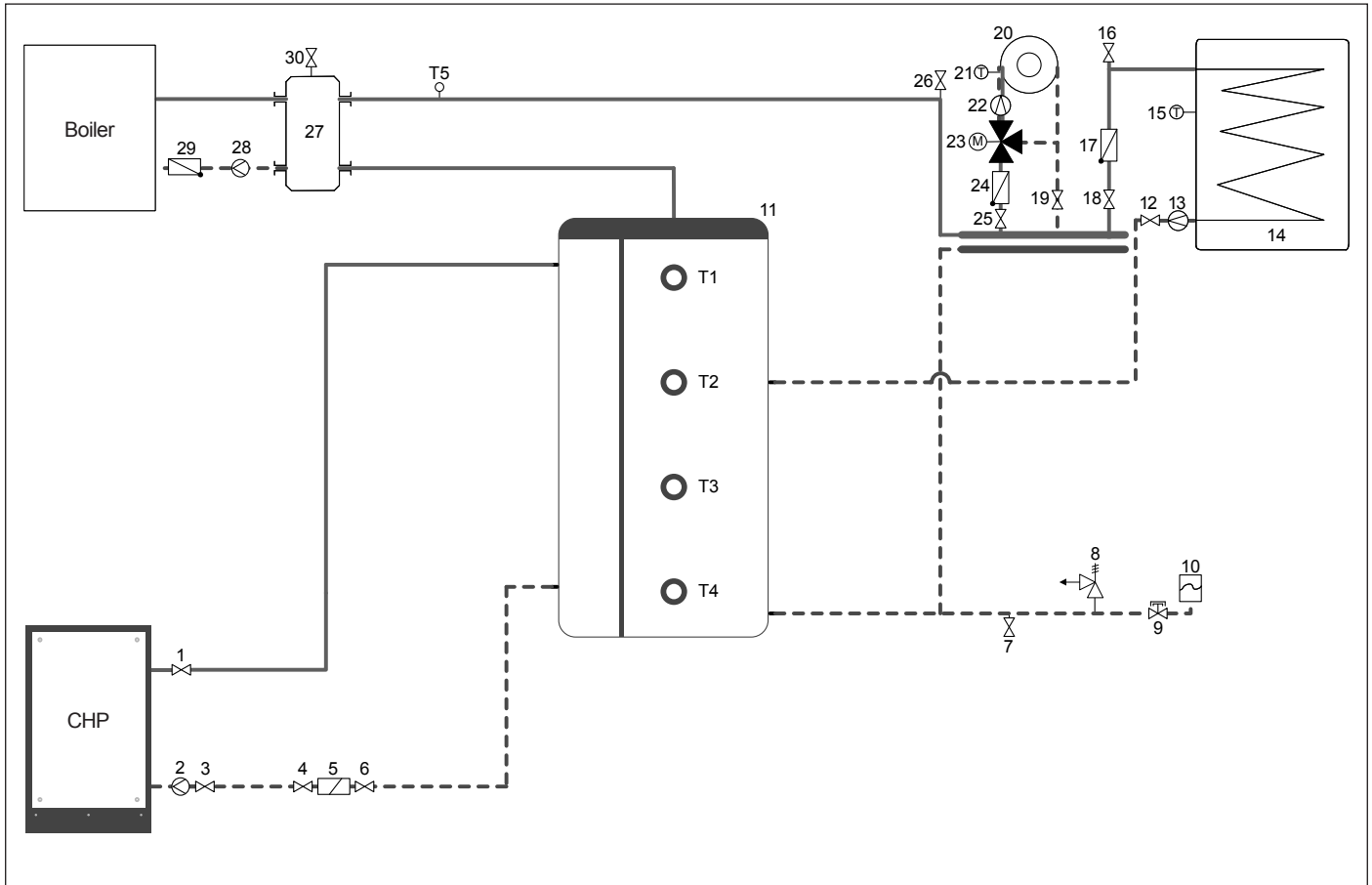

- | | | | |
|----|---------------------|----|---------------------------|
| 1 | Shut-off | 19 | Shut-off |
| 2 | Circulating pump | 20 | Heating circuit consumers |
| 3 | Shut-off | 21 | Temperature sensor |
| 4 | Shut-off | 22 | Circulating pump |
| 5 | Combination filter | 23 | 3-way mixer |
| 6 | Shut-off | 24 | Heating circuit consumers |
| 7 | Drain | 25 | Shut-off |
| 8 | Safety valve | 26 | Ventilation |
| 9 | Cap valve | 27 | Hydr. switches |
| 10 | Expansion tank | 28 | Circulating pump |
| 11 | Buffer tank | 29 | Non-return valve |
| 12 | Shut-off | 30 | Ventilation |
| 13 | Circulating pump | | |
| 14 | Drinking water tank | | |
| 15 | Temperature sensor | | |
| 16 | Ventilation | | |
| 17 | Non-return valve | | |
| 18 | Shut-off | | |

— Supply
 ... Return

12.2.2 Heating system variant 2 –

1 CHP, 2 buffer tanks, peak load boiler connected to buffer tank via hydraulic separator

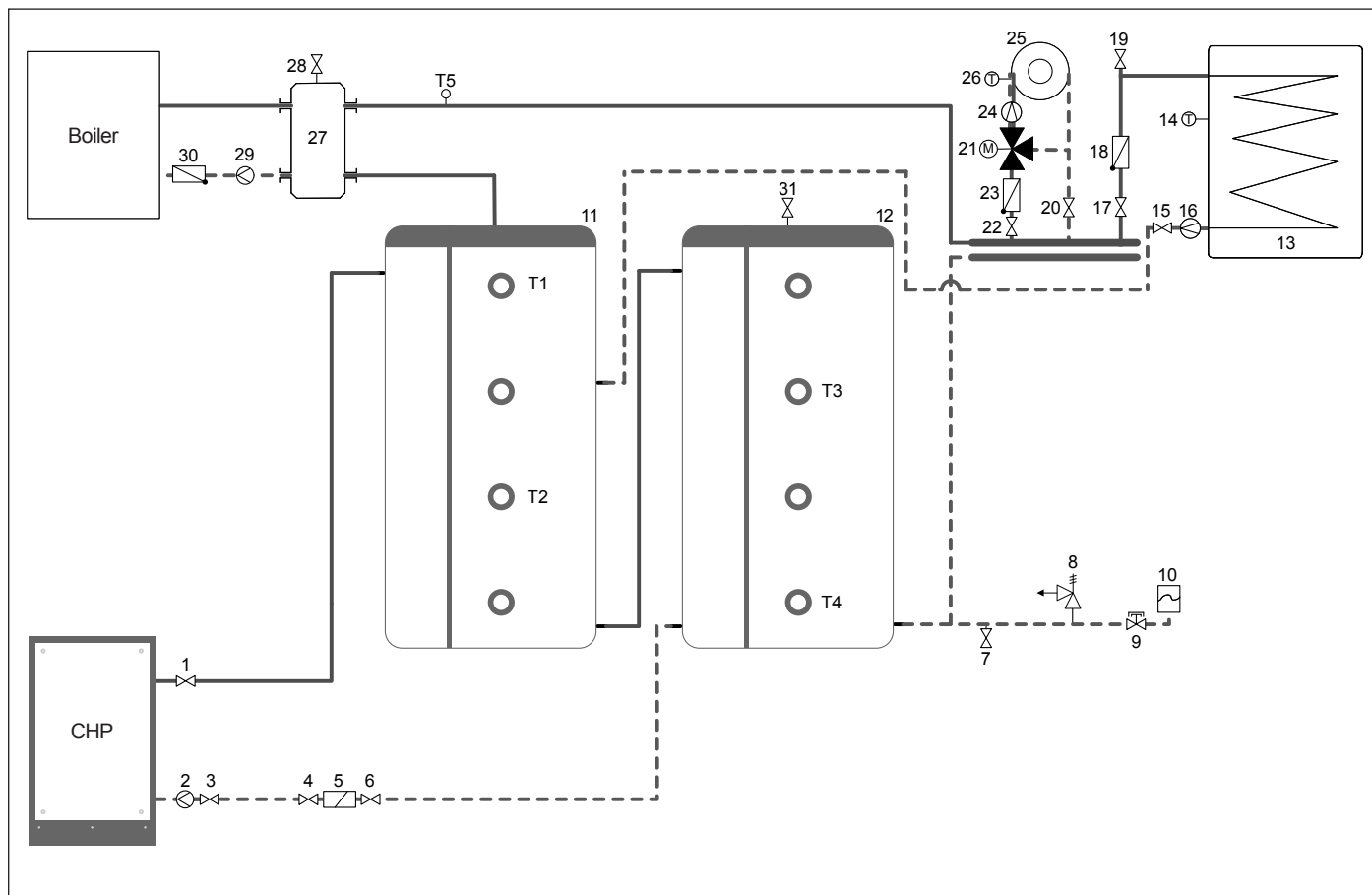

- 1 Shut-off
- 2 Circulating pump
- 3 Shut-off
- 4 Shut-off
- 5 Combination filter (if installed)
- 6 Shut-off
- 7 Drain
- 8 Safety valve
- 9 Cap valve
- 10 Pressure expansion vessel
- 11 Buffer tank
- 12 Buffer tank
- 13 Drinking water tank
- 14 Temperature sensor
- 15 Shut-off
- 16 Circulating pump
- 17 Shut-off
- 18 Non-return valve



- 19 Ventilation
- 20 Shut-off
- 21 3-way mixer
- 22 Shut-off
- 23 Non-return valve
- 24 Circulating pump
- 25 Heating circuit consumers
- 26 Temperature sensor
- 27 Hydr. switches
- 28 Ventilation
- 29 Circulating pump
- 30 Non-return valve
- 31 Ventilation

— Supply
 ... Return

Appendix

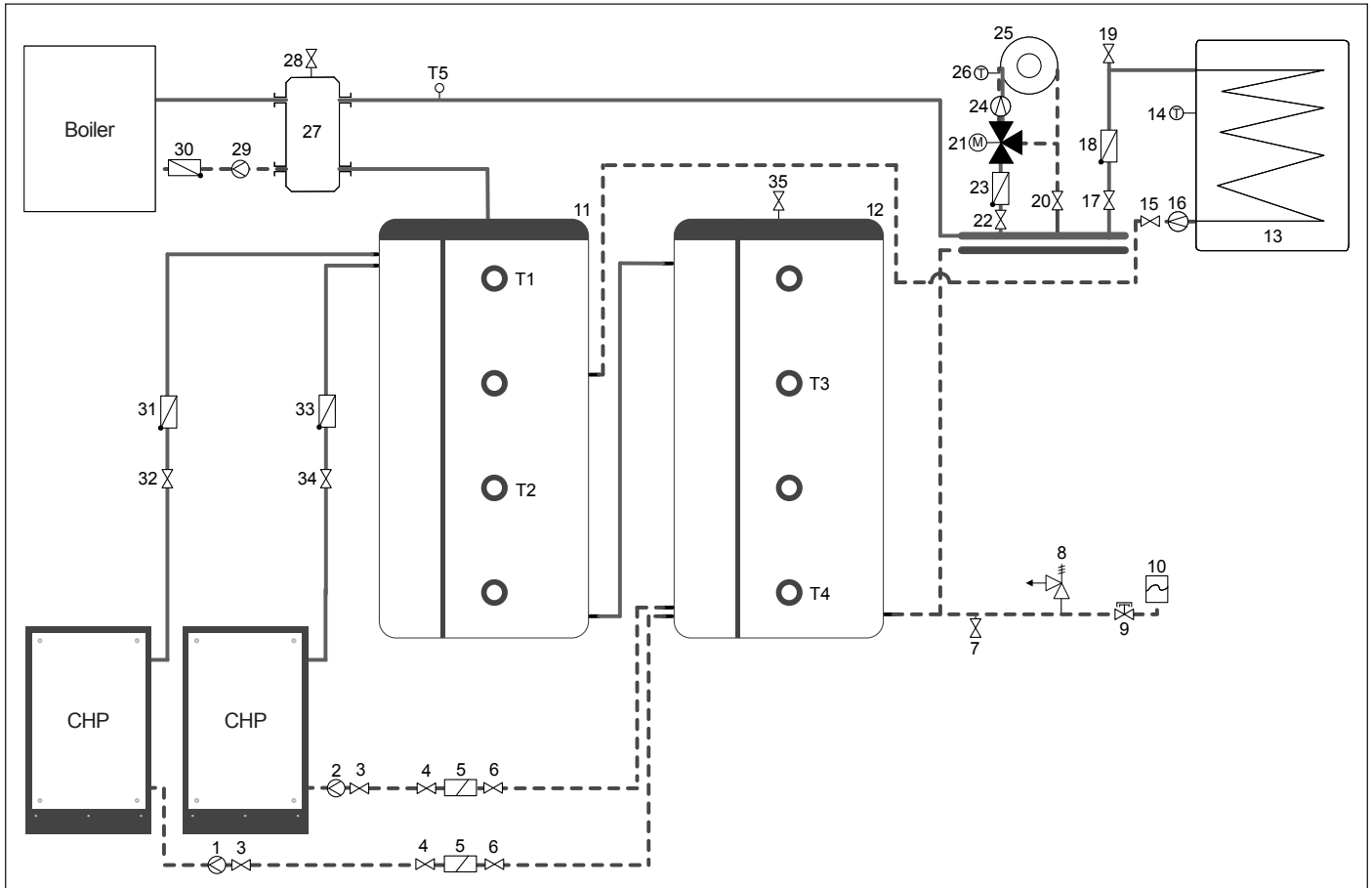
12.2.3 Heating system variant 3 – 2 CHP, 2 buffer tanks, peak load boiler connected to buffer tank via hydraulic separator



- | | | | |
|----|---------------------|----|---------------------------|
| 1 | Circulating pump | 21 | 3-way mixer |
| 2 | Circulating pump | 22 | Shut-off |
| 3 | Shut-off | 23 | Non-return valve |
| 4 | Shut-off | 24 | Circulating pump |
| 5 | Combination filter | 25 | Heating circuit consumers |
| 6 | Shut-off | 26 | Temperature sensor |
| 7 | Drain | 27 | Hydr. switches |
| 8 | Safety valve | 28 | Ventilation |
| 9 | Cap valve | 29 | Circulating pump |
| 10 | Expansion tank | 30 | Non-return valve |
| 11 | Buffer tank | 31 | Non-return valve |
| 12 | Buffer tank | 32 | Shut-off |
| 13 | Drinking water tank | 33 | Non-return valve |
| 14 | Temperature sensor | 34 | Shut-off |
| 15 | Shut-off | 35 | Ventilation |
| 16 | Circulating pump | | |
| 17 | Shut-off | | |
| 18 | Non-return valve | | |
| 19 | Ventilation | | |
| 20 | Shut-off | | |
-
- | | |
|-------------------------------------------------------------------------------------|--------|
|  | Supply |
|  | Return |



RMB/ENERGIE GmbH
Hauptstraße 543a
26683 Saterland, Germany

Tel.: +49 4498 92288-0
Fax: +49 4498 92288-66

info@rmbenergie.com
www.rmbenergie.com